

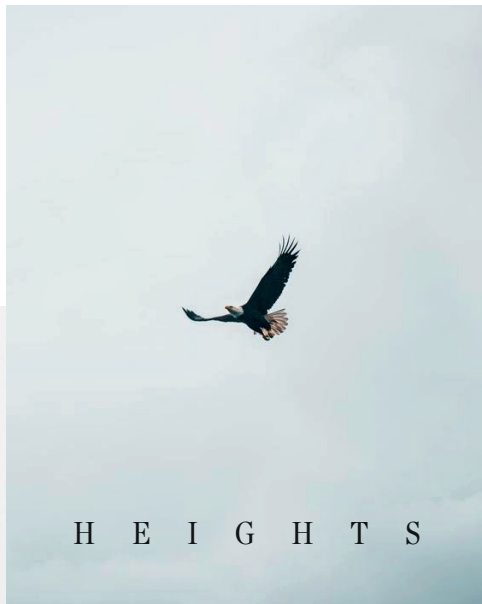

REACHING NEW

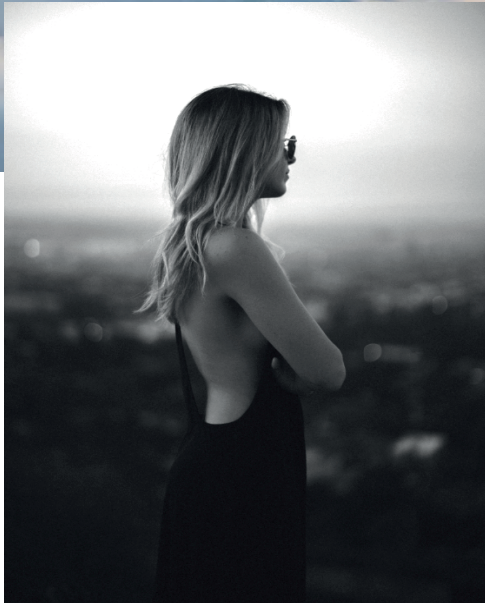

H E I G H T S



## LIVE ON CLOUD NINE

Two exquisite towers close to vibrant Downtown Dubai with high-end finishes and a unique charm that is truly unparalleled.



## THE HIGHEST BENCHMARKS

As a renowned developer, we endeavour to curate highly desirable locations, to realize our vision of elevating the lives of residents through thoughtfully crafted living spaces.





## GET HIGH ON LIFE

Whether marvelling at the golden sunset glistening on Dubai Canal during the day, or the city lights sparkling at night, life has never looked or felt so sensual.



# ENHANCE YOUR ASPIRATIONS

Relish a new level of luxury at a pre-eminent address. The height of contemporary living in 64 stories of world-class craftsmanship.

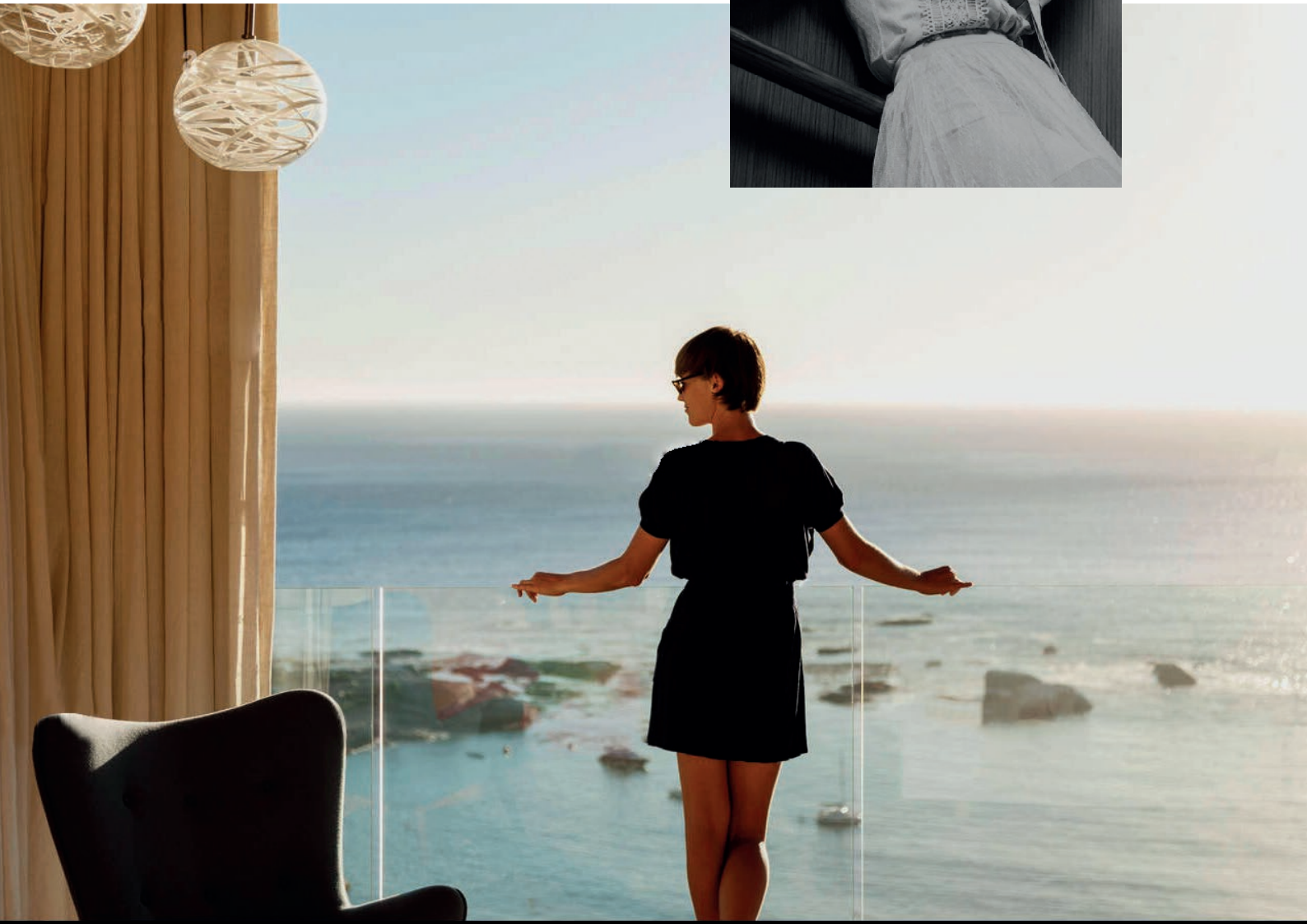

THE PEAK OF



P E R F E C T I O N





# THE HEIGHT OF SHEER CLASS

Bespoke residences that feature full-height windows to maximize all-encompassing views.







# BEAT THE SUN AS YOU TAKE A DIP

Take a plunge in a state-of-the-art swimming pool or work on those tan lines by the poolside, the choice is yours.





## UPLIFT YOUR SPIRITS

Be your best self, courtesy of a fully equipped gym that promises exceptional facilities, designed to relieve the stresses of the day, every day.

RELAX YOUR BODY.  
REFINE YOUR  
SENSES

Elegant, opulent yet still practical, a premium apartment featuring a new level of refinement awaits you, every day.





## RAISE A TOAST AMONGST FRIENDS

Capture the pulse of the city, where leisure and pleasure seamlessly blend into magical moments within the Hartland community.

# HOP A LITTLE, JUMP A LITTLE

Specially carved out areas for the little ones in the family to play to their hearts' content. Uninterrupted.





## IDEAL SPACES TO SOCIALISE

Connect with people as discerning as you are. Meet others who share the same interest as you do, or simply enjoy the feeling of being part of a community.



1-3.5 Bedroom  
Bespoke Luxury Apartments Starting from

AED 1.22 Million\*

PAYMENT PLAN

60%

During Construction

40%

On Completion





# LOCATION PLAN



RAS AL KHOR  
WILDLIFE SANCTUARY



DUBAI CREEK



DOWNTOWN



MEYDAN ONE MALL



MEYDAN RACECOURSE

## APARTMENT FEATURES



Landmark views



Covered car parking



Fully fitted kitchens



Bedroom wardrobe in all units

# FLOOR PLAN LAYOUT



**TOWER A**  
LEVEL 10 - 26 & 28 - 32

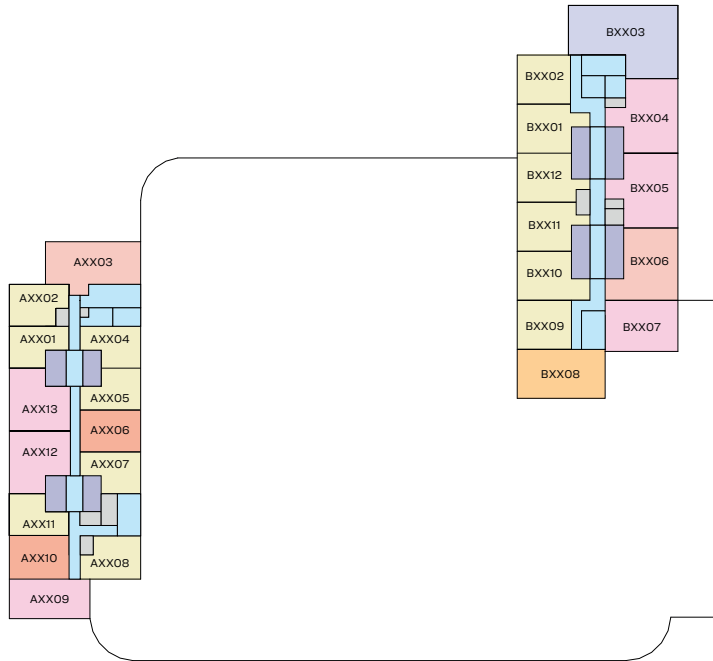

**TOWER B**  
LEVEL 10 - 32

**TOWER A**  
LEVEL 33 - 51

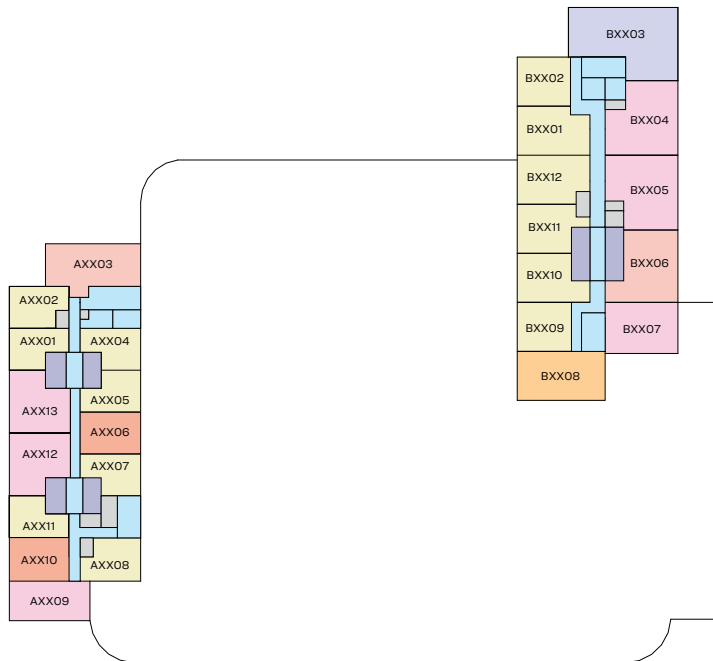

**TOWER B**  
LEVEL 34 - 57

- |   |   |  |
|---|---|--|
| <span style="display:inline-block; width:15px; height:15px; background-color:#f0e68c; border:1px solid black;"></span> 1 BED UNIT   | <span style="display:inline-block; width:15px; height:15px; background-color:#f08080; border:1px solid black;"></span> 2.5 BED UNIT | <span style="display:inline-block; width:15px; height:15px; background-color:#add8e6; border:1px solid black;"></span> CIRCULATION |
| <span style="display:inline-block; width:15px; height:15px; background-color:#ffa07a; border:1px solid black;"></span> 1.5 BED UNIT | <span style="display:inline-block; width:15px; height:15px; background-color:#ffa500; border:1px solid black;"></span> 3 BED UNIT   | <span style="display:inline-block; width:15px; height:15px; background-color:#6a5acd; border:1px solid black;"></span> LIFT        |
| <span style="display:inline-block; width:15px; height:15px; background-color:#ffb6c1; border:1px solid black;"></span> 2 BED UNIT   | <span style="display:inline-block; width:15px; height:15px; background-color:#9370db; border:1px solid black;"></span> 3.5 BED UNIT | <span style="display:inline-block; width:15px; height:15px; background-color:#a9a9a9; border:1px solid black;"></span> SERVICES    |

Disclaimer: 1. All dimensions are in metric, measured to wall finishes. 2. All materials, dimensions & drawings are approximate. 3. Information is subject to change without notice, at developer's absolute discretion. 4. Actual area may vary from the stated area. 5. Drawing are not to scale. 6. All images used are for illustrative purpose only and do not represent the actual size, features, specifications, fittings and furnishings. 7. The developer reserves the right to make revisions/ alterations, at its absolute discretion, without any liability whatsoever.

**TOWER A**  
**UNIT PLANS**

# 1 BEDROOM APARTMENT

TYPE A (with balcony)

**TOTAL SALEABLE AREA**

SUITE = 553.48 SQ.FT.

BALCONY = 57.59 SQ.FT.

TOTAL = 611.07 SQ.FT.

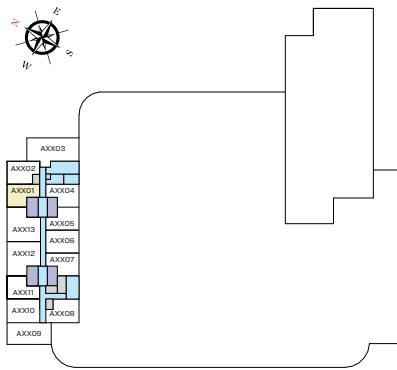

LEVEL 10 - 26 & 28 - 51

UNIT

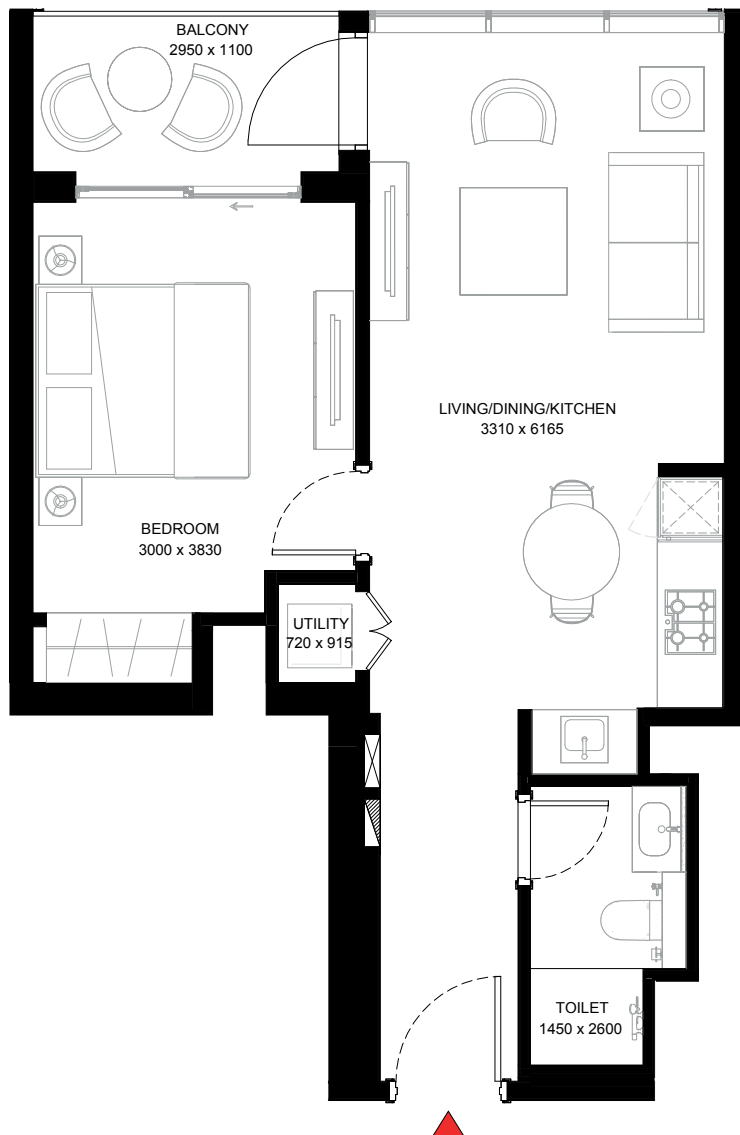
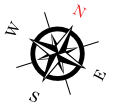

List of unit numbers with this unit plan:

## VIEWS

Burj Khalifa, Downtown, Dubai Water Canal

A1001, A1101, A1201, A1301, A1401, A1501, A1601, A1701, A1801, A1901, A2001, A2101, A2201, A2301, A2401, A2501, A2601, A2801, A2901, A3001, A3101, A3201, A3301, A3401, A3501, A3601, A3701, A3801, A3901, A4001, A4101, A4201, A4301, A4401, A4501, A4601, A4701, A4801, A4901, A5001, A5101

Disclaimer: 1. All dimensions are in metric, measured to wall finishes. 2. All materials, dimensions & drawings are approximate. 3. Information is subject to change without notice, at developer's absolute discretion. 4. Actual area may vary from the stated area. 5. Drawing are not to scale. 6. All images used are for illustrative purpose only and do not represent the actual size, features, specifications, fittings and furnishings. 7. The developer reserves the right to make revisions/ alterations, at its absolute discretion, without any liability whatsoever.

# 1 BEDROOM APARTMENT

TYPE A (with balcony) - VARIANT 1

**TOTAL SALEABLE AREA**

SUITE = 553.48 SQ.FT.

BALCONY = 57.59 SQ.FT.

TOTAL = 611.07 SQ.FT.

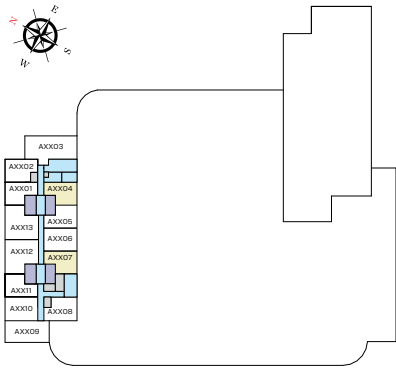

LEVEL 10 - 26 & 28 - 51

UNIT

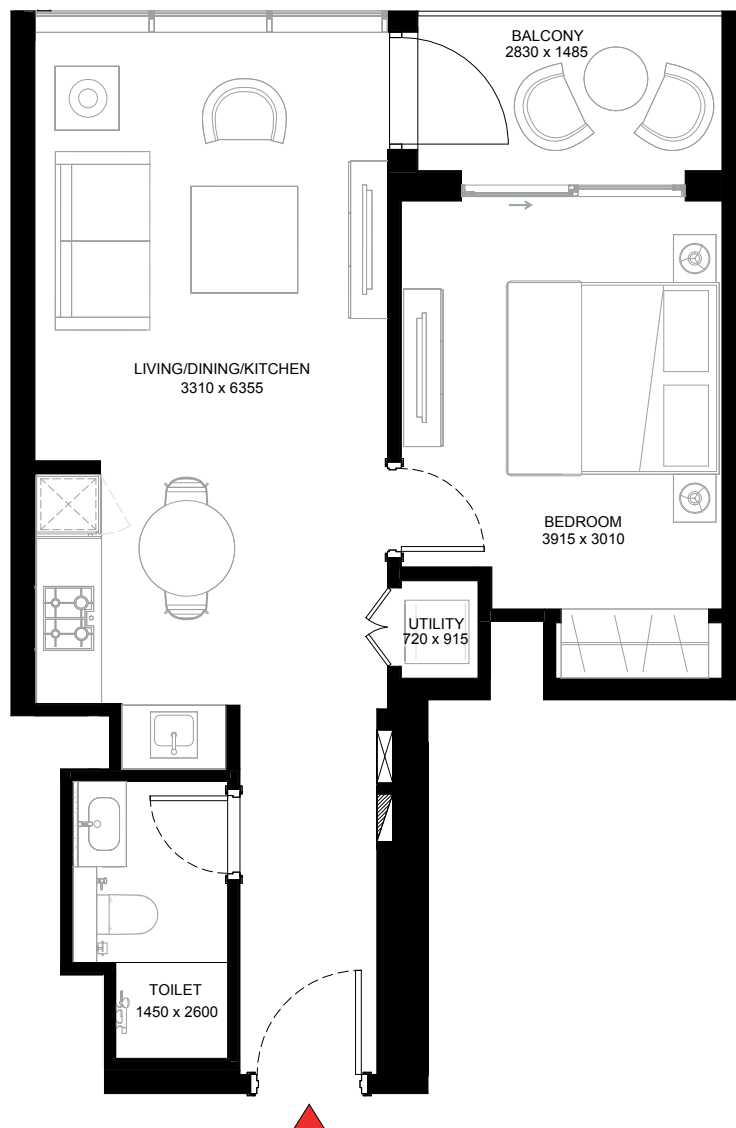

List of unit numbers with this unit plan:

## VIEWS

Ras Al Khor Sanctuary, Hartland, Amenities

A1004, A1007, A1104, A1107, A1204, A1207, A1304, A1307

Ras Al Khor Sanctuary, Hartland

A1404, A1407, A1504, A1507, A1604, A1607, A1704, A1707, A1804, A1807, A1904, A1907, A2004, A2007, A2104, A2107, A2204, A2207, A2304, A2307, A2404, A2407, A2504, A2507, A2604, A2607, A2804, A2807, A2904, A2907, A3004, A3007, A3104, A3107, A3204, A3207, A3304, A3307, A3404, A3407, A3504, A3507, A3604, A3607, A3704, A3707, A3804, A3807, A3904, A3907, A4004, A4007, A4104, A4107, A4204, A4207, A4304, A4307, A4404, A4407, A4504, A4507, A4604, A4607, A4704, A4707, A4804, A4807, A4904, A4907, A5004, A5007, A5104, A5107

Disclaimer: 1. All dimensions are in metric, measured to wall finishes. 2. All materials, dimensions & drawings are approximate. 3. Information is subject to change without notice, at developer's absolute discretion. 4. Actual area may vary from the stated area. 5. Drawing are not to scale. 6. All images used are for illustrative purpose only and do not represent the actual size, features, specifications, fittings and furnishings. 7. The developer reserves the right to make revisions/ alterations, at its absolute discretion, without any liability whatsoever.

# 1 BEDROOM APARTMENT

TYPE A (with balcony) - VARIANT 2

**TOTAL SALEABLE AREA**

SUITE = 553.48 SQ.FT.

BALCONY = 57.59 SQ.FT.

TOTAL = 611.07 SQ.FT.

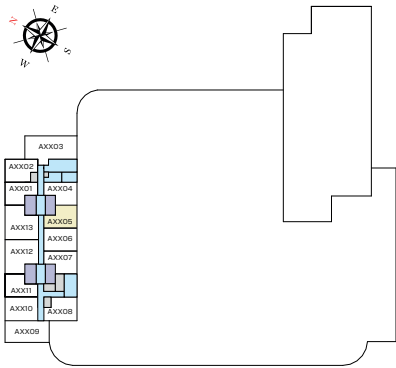

LEVEL 10 - 26 & 28 - 51

UNIT

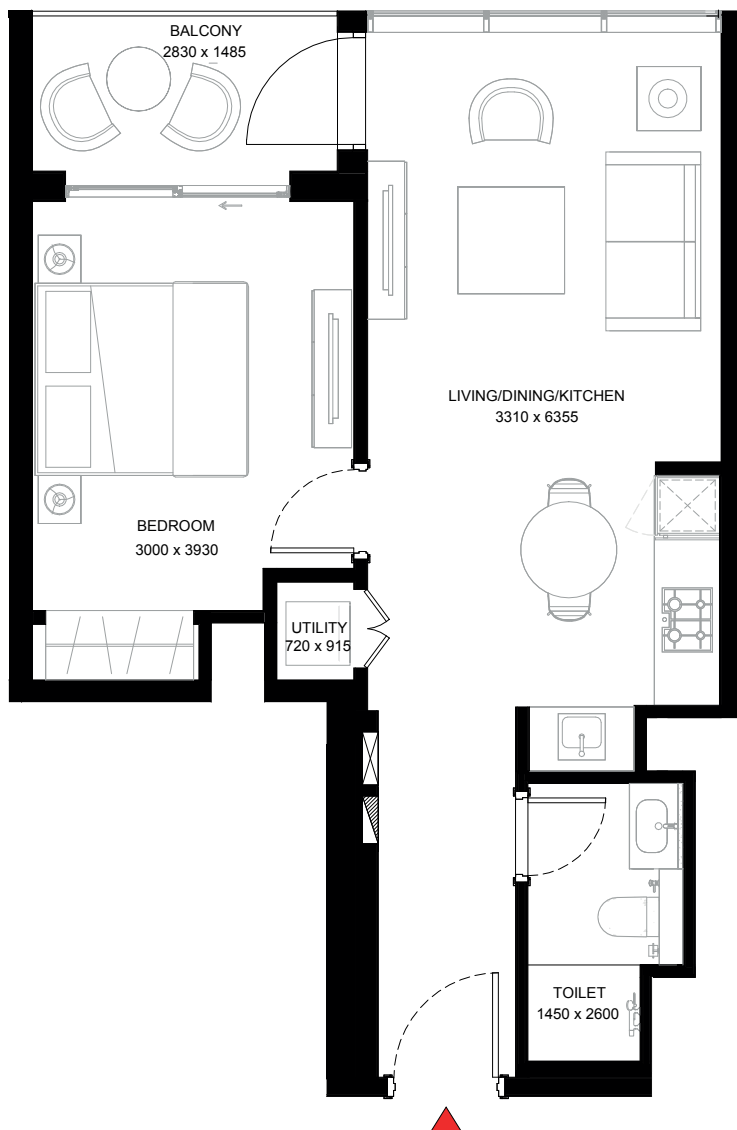

List of unit numbers with this unit plan:

## VIEWS

Ras Al Khor Sanctuary, Hartland, Amenities  
A1005, A1105, A1205, A1305

Ras Al Khor Sanctuary, Hartland

A1405, A1505, A1605, A1705, A1805, A1905, A2005, A2105, A2205, A2305, A2405, A2505, A2605, A2805, A2905, A3005, A3105, A3205, A3305, A3405, A3505, A3605, A3705, A3805, A3905, A4005, A4105, A4205, A4305, A4405, A4505, A4605, A4705, A4805, A4905, A5005, A5105

Disclaimer: 1. All dimensions are in metric, measured to wall finishes. 2. All materials, dimensions & drawings are approximate. 3. Information is subject to change without notice, at developer's absolute discretion. 4. Actual area may vary from the stated area. 5. Drawing are not to scale. 6. All images used are for illustrative purpose only and do not represent the actual size, features, specifications, fittings and furnishings. 7. The developer reserves the right to make revisions/ alterations, at its absolute discretion, without any liability whatsoever.

# 1 BEDROOM APARTMENT

TYPE A (with balcony) - VARIANT 3

**TOTAL SALEABLE AREA**

SUITE = 553.48 SQ.FT.

BALCONY = 57.59 SQ.FT.

TOTAL = 611.07 SQ.FT.



LEVEL 10 - 26 & 28 - 51

UNIT

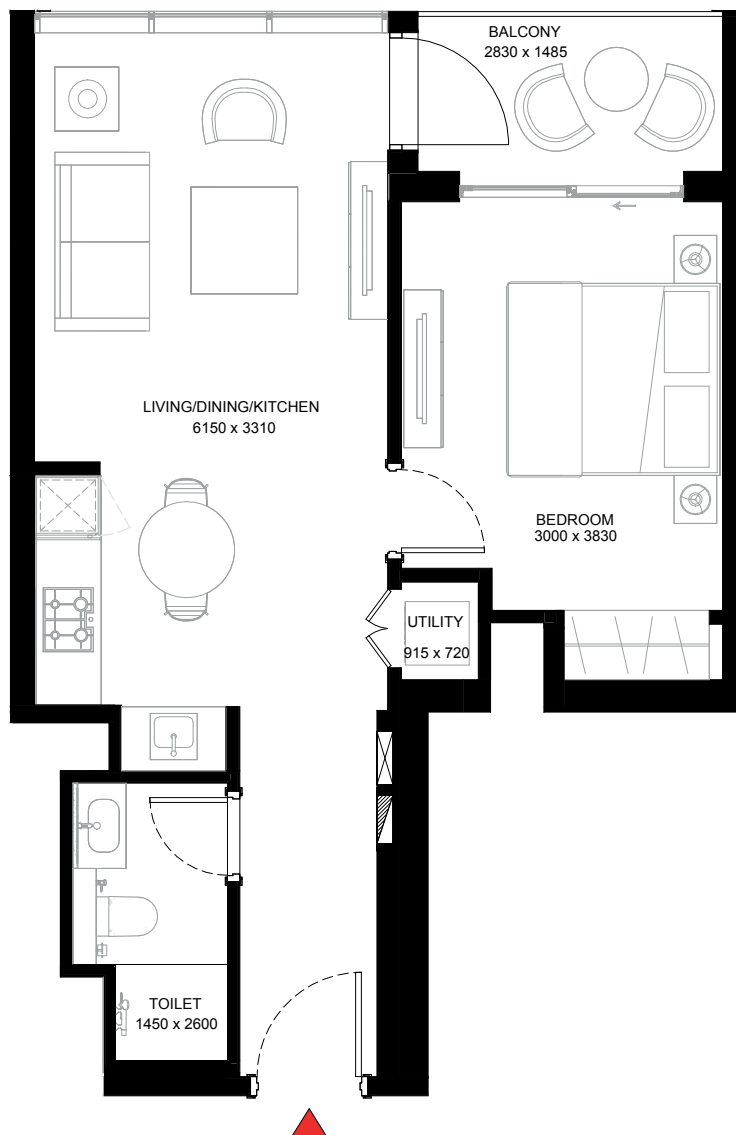
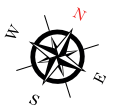

List of unit numbers with this unit plan:

## VIEWS

Burj Khalifa, Downtown, Dubai Water Canal

A1011, A1111, A1211, A1311, A1411, A1511, A1611, A1711, A1811, A1911, A2011, A2111, A2211, A2311, A2411, A2511, A2611, A2811, A2911, A3011, A3111, A3211, A3311, A3411, A3511, A3611, A3711, A3811, A3911, A4011, A4111, A4211, A4311, A4411, A4511, A4611, A4711, A4811, A4911, A5011, A5111

Disclaimer: 1. All dimensions are in metric, measured to wall finishes. 2. All materials, dimensions & drawings are approximate. 3. Information is subject to change without notice, at developer's absolute discretion. 4. Actual area may vary from the stated area. 5. Drawing are not to scale. 6. All images used are for illustrative purpose only and do not represent the actual size, features, specifications, fittings and furnishings. 7. The developer reserves the right to make revisions/ alterations, at its absolute discretion, without any liability whatsoever.

# 1 BEDROOM APARTMENT

TYPE C (with balcony)

**TOTAL SALEABLE AREA**

SUITE = 590.40 SQ.FT.

BALCONY = 59.63 SQ.FT.

TOTAL = 650.03 SQ.FT.

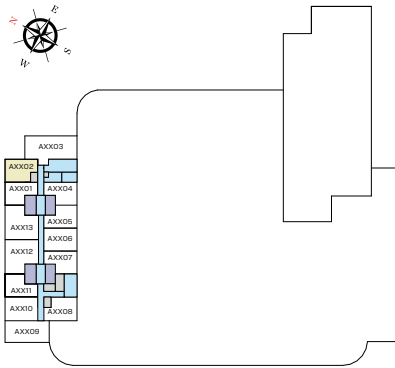

LEVEL 10 - 26 & 28 - 51

UNIT

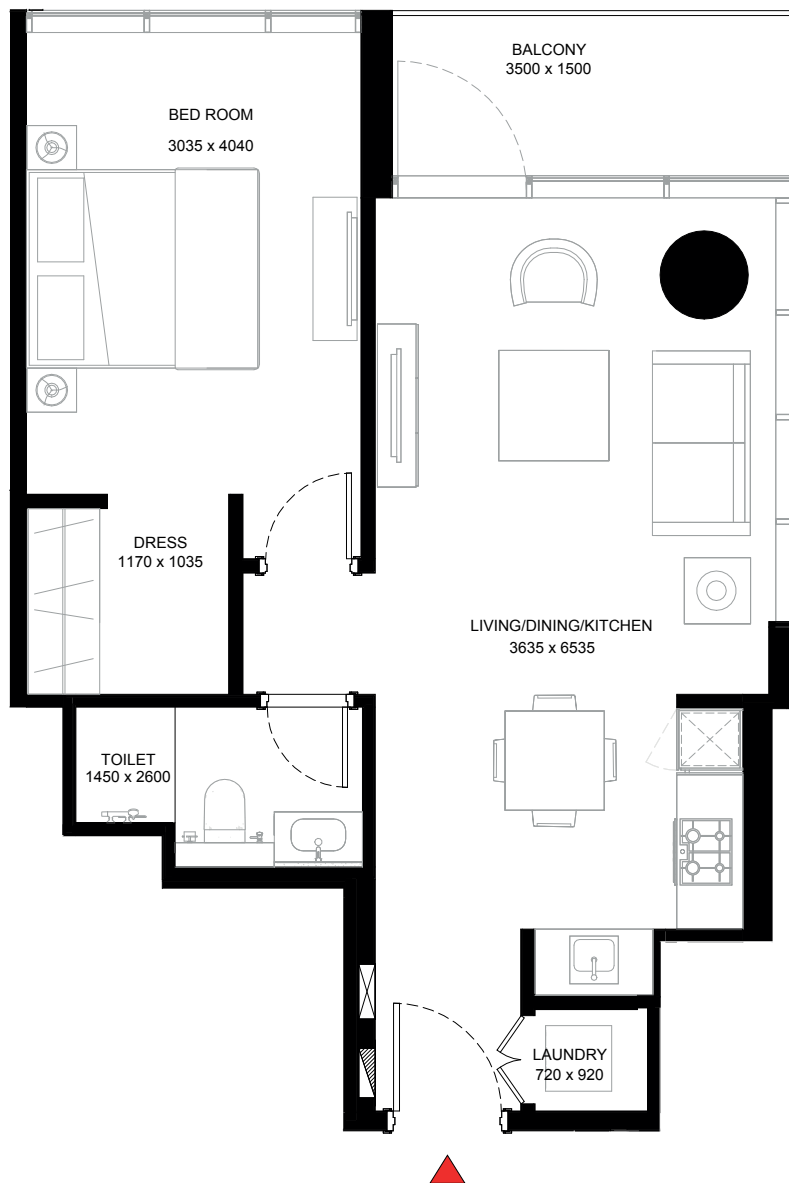
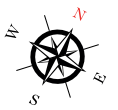

List of unit numbers with this unit plan:

## VIEWS

Burj Khalifa, Downtown, Dubai Water Canal, Ras Al Khor Sanctuary

A1002, A1102, A1202, A1302, A1402, A1502, A1602, A1702, A1802, A1902, A2002, A2102, A2202, A2302, A2402, A2502, A2602, A2802, A2902, A3002, A3102, A3202, A3302, A3402, A3502, A3602, A3702, A3802, A3902, A4002, A4102, A4202, A4302, A4402, A4502, A4602, A4702, A4802, A4902, A5002, A5102

Disclaimer: 1. All dimensions are in metric, measured to wall finishes. 2. All materials, dimensions & drawings are approximate. 3. Information is subject to change without notice, at developer's absolute discretion. 4. Actual area may vary from the stated area. 5. Drawing are not to scale. 6. All images used are for illustrative purpose only and do not represent the actual size, features, specifications, fittings and furnishings. 7. The developer reserves the right to make revisions/ alterations, at its absolute discretion, without any liability whatsoever.



# 1 BEDROOM APARTMENT

TYPE C (with balcony) - VARIANT 1

**TOTAL SALEABLE AREA**

SUITE = 588.25 SQ.FT.

BALCONY = 61.35 SQ.FT.

TOTAL = 649.60 SQ.FT.

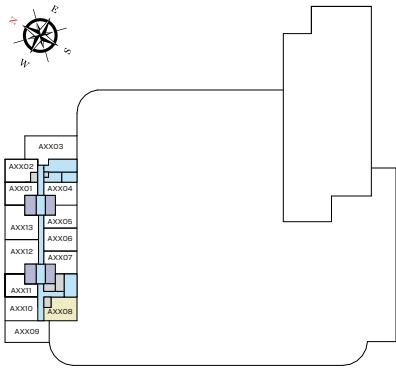

LEVEL 10 - 26 & 28 - 51

UNIT

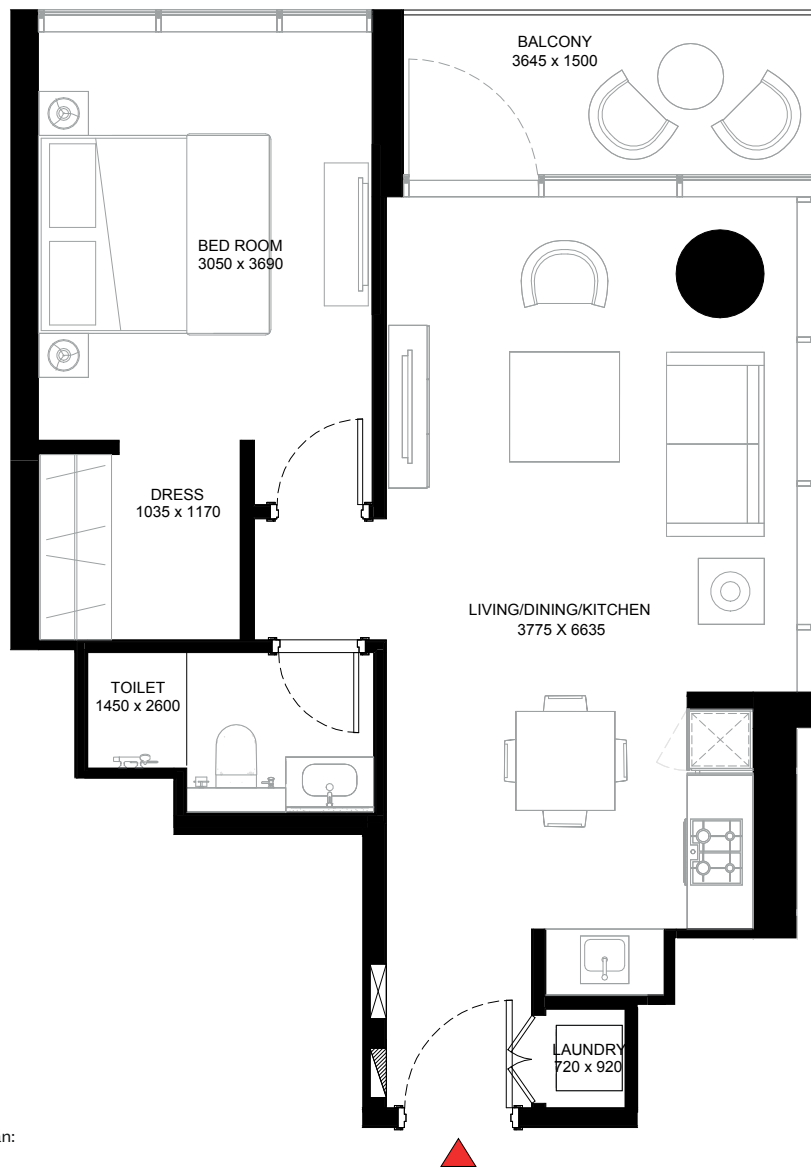

List of unit numbers with this unit plan:

## VIEWS

Ras Al Khor Sanctuary, Hartland, Amenities  
A1008, A1108, A1208, A1308

Ras Al Khor Sanctuary, Hartland

A1408, A1508, A1608, A1708, A1808, A1908, A2008, A2108, A2208, A2308, A2408, A2508, A2608, A2808, A2908, A3008, A3108, A3208, A3308, A3408, A3508, A3608, A3708, A3808, A3908, A4008, A4108, A4208, A4308, A4408, A4508, A4608, A4708, A4808, A4908, A5008, A5108

Disclaimer: 1. All dimensions are in metric, measured to wall finishes. 2. All materials, dimensions & drawings are approximate. 3. Information is subject to change without notice, at developer's absolute discretion. 4. Actual area may vary from the stated area. 5. Drawing are not to scale. 6. All images used are for illustrative purpose only and do not represent the actual size, features, specifications, fittings and furnishings. 7. The developer reserves the right to make revisions/ alterations, at its absolute discretion, without any liability whatsoever.

# 1.5 BEDROOM APARTMENT

TYPE A (with study and powder room + balcony)

**TOTAL SALEABLE AREA**

SUITE = 661.87 SQ.FT.

BALCONY = 57.59 SQ.FT.

TOTAL = 719.46 SQ.FT.

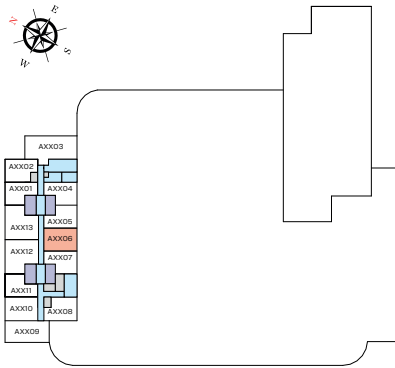

LEVEL 10 - 26 & 28 - 51

UNIT

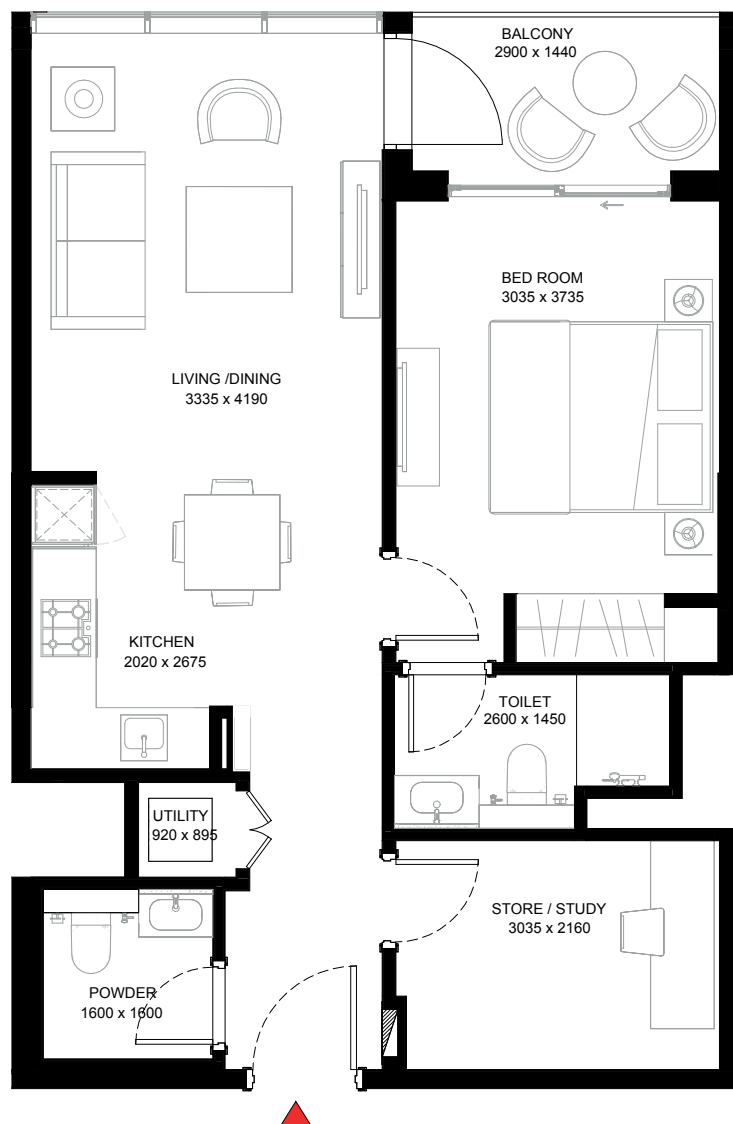

List of unit numbers with this unit plan:

## VIEWS

Ras Al Khor Sanctuary, Hartland, Amenities  
A1006, A1106, A1206, A1306

Ras Al Khor Sanctuary, Hartland

A1406, A1506, A1606, A1706, A1806, A1906, A2006, A2106, A2206, A2306, A2406, A2506, A2606, A2806, A2906, A3006, A3106, A3206, A3306, A3406, A3506, A3606, A3706, A3806, A3906, A4006, A4106, A4206, A4306, A4406, A4506, A4606, A4706, A4806, A4906, A5006, A5106

Disclaimer: 1. All dimensions are in metric, measured to wall finishes. 2. All materials, dimensions & drawings are approximate. 3. Information is subject to change without notice, at developer's absolute discretion. 4. Actual area may vary from the stated area. 5. Drawing are not to scale. 6. All images used are for illustrative purpose only and do not represent the actual size, features, specifications, fittings and furnishings. 7. The developer reserves the right to make revisions/ alterations, at its absolute discretion, without any liability whatsoever.

# 1.5 BEDROOM APARTMENT

TYPE A (with study and powder room + balcony) - VARIANT 1

**TOTAL SALEABLE AREA**

SUITE = 661.77 SQ.FT.

BALCONY = 57.59 SQ.FT.

TOTAL = 719.36 SQ.FT.

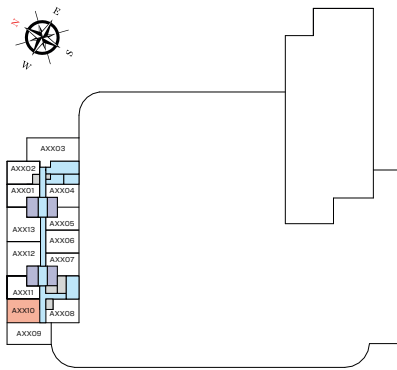

LEVEL 10 - 26 & 28 - 51

UNIT

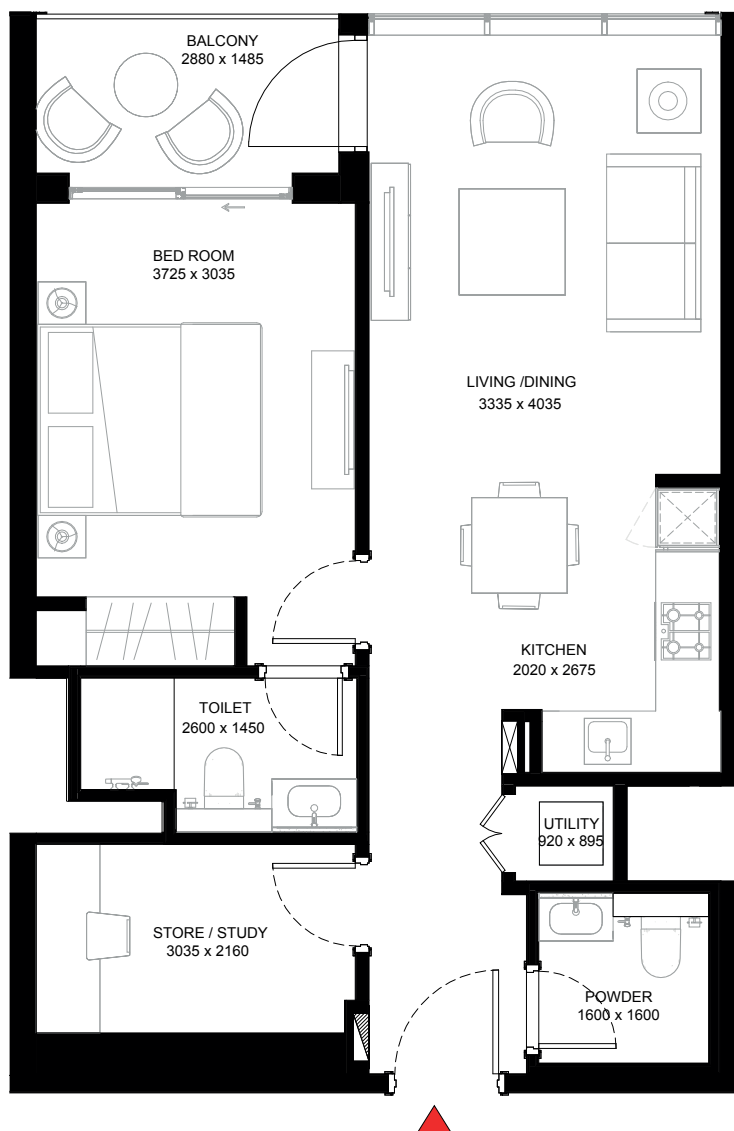
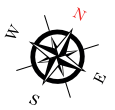

List of unit numbers with this unit plan:

## VIEWS

Burj Khalifa, Downtown, Dubai Water Canal

A1010, A1110, A1210, A1310, A1410, A1510, A1610, A1710, A1810, A1910, A2010, A2110, A2210, A2310, A2410, A2510, A2610, A2810, A2910, A3010, A3110, A3210, A3310, A3410, A3510, A3610, A3710, A3810, A3910, A4010, A4110, A4210, A4310, A4410, A4510, A4610, A4710, A4810, A4910, A5010, A5110

Disclaimer: 1. All dimensions are in metric, measured to wall finishes. 2. All materials, dimensions & drawings are approximate. 3. Information is subject to change without notice, at developer's absolute discretion. 4. Actual area may vary from the stated area. 5. Drawing are not to scale. 6. All images used are for illustrative purpose only and do not represent the actual size, features, specifications, fittings and furnishings. 7. The developer reserves the right to make revisions/ alterations, at its absolute discretion, without any liability whatsoever.

# 2 BEDROOM APARTMENT

TYPE A (with balcony)

## TOTAL SALEABLE AREA

SUITE = 893.94 SQ.FT.

BALCONY = 56.73 SQ.FT.

TOTAL = 950.67 SQ.FT.

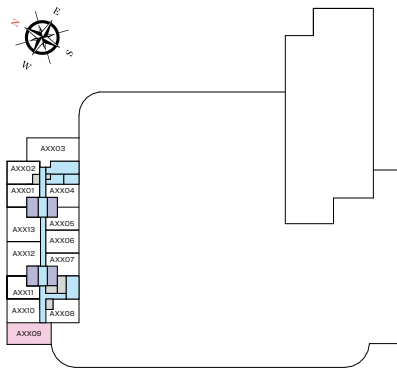

LEVEL 10 - 26 & 28 - 51

UNIT



List of unit numbers with this unit plan:

## VIEWS

Burj Khalifa, Downtown, Dubai Water Canal, Hartland, Amenities  
A1009, A1109, A1209, A1309

Burj Khalifa, Downtown, Dubai Water Canal, Hartland

A1409, A1509, A1609, A1709, A1809, A1909, A2009, A2109, A2209, A2309, A2409, A2509, A2609, A2809, A2909, A3009, A3109, A3209, A3309, A3409, A3509, A3609, A3709, A3809, A3909, A4009, A4109, A4209, A4309, A4409, A4509, A4609, A4709, A4809, A4909, A5009, A5109

Disclaimer: 1. All dimensions are in metric, measured to wall finishes. 2. All materials, dimensions & drawings are approximate. 3. Information is subject to change without notice, at developer's absolute discretion. 4. Actual area may vary from the stated area. 5. Drawing are not to scale. 6. All images used are for illustrative purpose only and do not represent the actual size, features, specifications, fittings and furnishings. 7. The developer reserves the right to make revisions/ alterations, at its absolute discretion, without any liability whatsoever.

# 2 BEDROOM APARTMENT

TYPE B (with 2 balconies)

**TOTAL SALEABLE AREA**

SUITE = 854.22 SQ.FT.

BALCONY = 113.45 SQ.FT.

TOTAL = 967.67 SQ.FT.

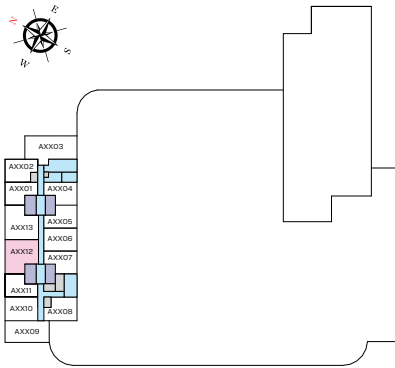

LEVEL 10 - 26 & 28 - 51

UNIT

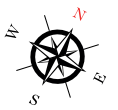

List of unit numbers with this unit plan:

## VIEWS

Burj Khalifa, Downtown, Dubai Water Canal

A1012, A1112, A1212, A1312, A1412, A1512, A1612, A1712, A1812, A1912, A2012, A2112, A2212, A2312, A2412, A2512, A2612, A2812, A2912, A3012, A3112, A3212, A3312, A3412, A3512, A3612, A3712, A3812, A3912, A4012, A4112, A4212, A4312, A4412, A4512, A4612, A4712, A4812, A4912, A5012, A5112

Disclaimer: 1. All dimensions are in metric, measured to wall finishes. 2. All materials, dimensions & drawings are approximate. 3. Information is subject to change without notice, at developer's absolute discretion. 4. Actual area may vary from the stated area. 5. Drawing are not to scale. 6. All images used are for illustrative purpose only and do not represent the actual size, features, specifications, fittings and furnishings. 7. The developer reserves the right to make revisions/ alterations, at its absolute discretion, without any liability whatsoever.

# 2 BEDROOM APARTMENT

TYPE B (with 2 balconies) - VARIANT 1

**TOTAL SALEABLE AREA**

SUITE = 854.22 SQ.FT.

BALCONY = 113.45 SQ.FT.

TOTAL = 967.67 SQ.FT.

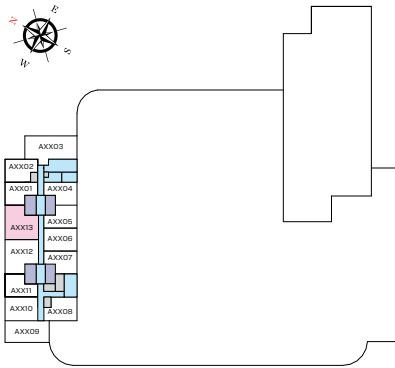

LEVEL 10 - 26 & 28 - 51

UNIT

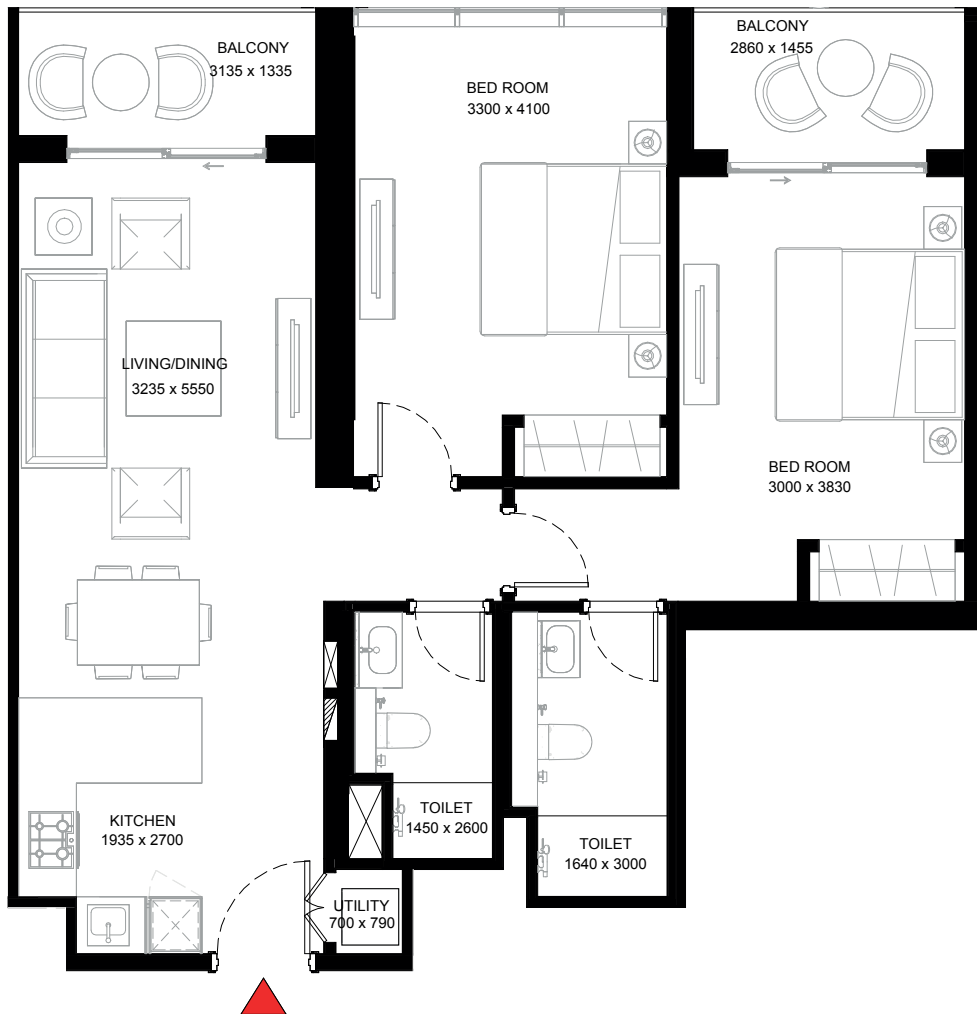
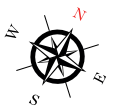

List of unit numbers with this unit plan:

## VIEWS

Burj Khalifa, Downtown, Dubai Water Canal

A1013, A1113, A1213, A1313, A1413, A1513, A1613, A1713, A1813, A1913, A2013, A2113, A2213, A2313, A2413, A2513, A2613, A2813, A2913, A3013, A3113, A3213, A3313, A3413, A3513, A3613, A3713, A3813, A3913, A4013, A4113, A4213, A4313, A4413, A4513, A4613, A4713, A4813, A4913, A5013, A5113

Disclaimer: 1. All dimensions are in metric, measured to wall finishes. 2. All materials, dimensions & drawings are approximate. 3. Information is subject to change without notice, at developer's absolute discretion. 4. Actual area may vary from the stated area. 5. Drawing are not to scale. 6. All images used are for illustrative purpose only and do not represent the actual size, features, specifications, fittings and furnishings. 7. The developer reserves the right to make revisions/ alterations, at its absolute discretion, without any liability whatsoever.

## 2.5 BEDROOM APARTMENT

TYPE A (with study and powder room + balcony)

**TOTAL SALEABLE AREA**

SUITE = 1,117.51 SQ.FT.

BALCONY = 55.54 SQ.FT.

TOTAL = 1,173.05 SQ.FT.

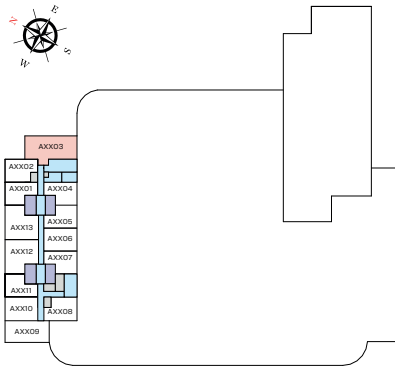

LEVEL 10 - 26 & 28 - 51

UNIT

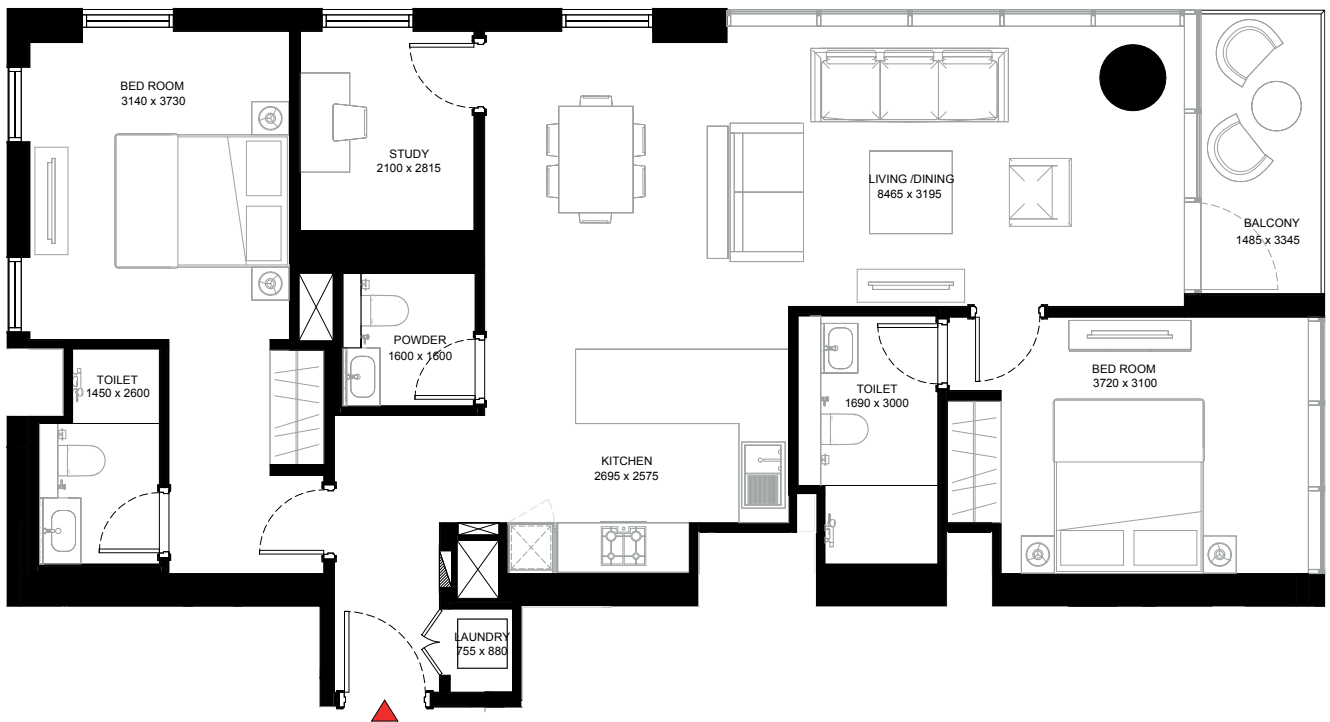
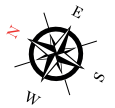

List of unit numbers with this unit plan:

### VIEWS

Burj Khalifa, Downtown, Dubai Water Canal, Ras Al Khor Sanctuary, Hartland, Amenities  
A1003, A1103, A1203, A1303

Burj Khalifa, Downtown, Dubai Water Canal, Ras Al Khor Sanctuary, Hartland

A1403, A1503, A1603, A1703, A1803, A1903, A2003, A2103, A2203, A2303, A2403, A2503, A2603, A2803, A2903, A3003, A3103, A3203, A3303, A3403, A3503, A3603, A3703, A3803, A3903, A4003, A4103, A4203, A4303, A4403, A4503, A4603, A4703, A4803, A4903, A5003, A5103

Disclaimer: 1. All dimensions are in metric, measured to wall finishes. 2. All materials, dimensions & drawings are approximate. 3. Information is subject to change without notice, at developer's absolute discretion. 4. Actual area may vary from the stated area. 5. Drawing are not to scale. 6. All images used are for illustrative purpose only and do not represent the actual size, features, specifications, fittings and furnishings. 7. The developer reserves the right to make revisions/ alterations, at its absolute discretion, without any liability whatsoever.

**TOWER B**  
UNIT PLANS



# 1 BEDROOM APARTMENT

## TYPE D (with powder room + balcony)

**TOTAL SALEABLE AREA**

SUITE = 676.51 SQ.FT.

BALCONY = 66.63 SQ.FT.

TOTAL = 743.14 SQ.FT.

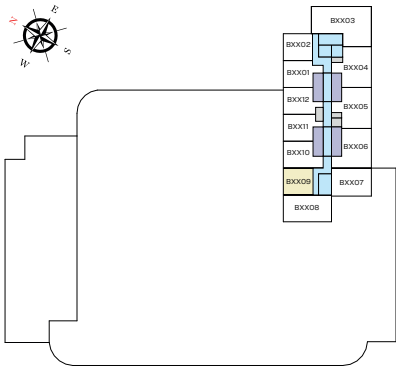

LEVEL 10 - 32

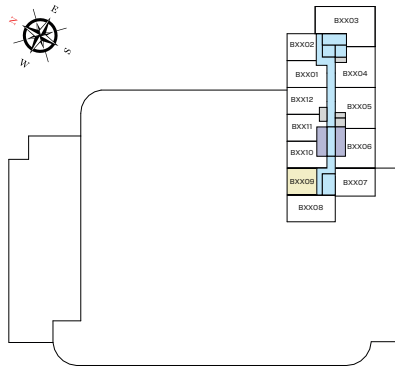

LEVEL 34 - 57

UNIT

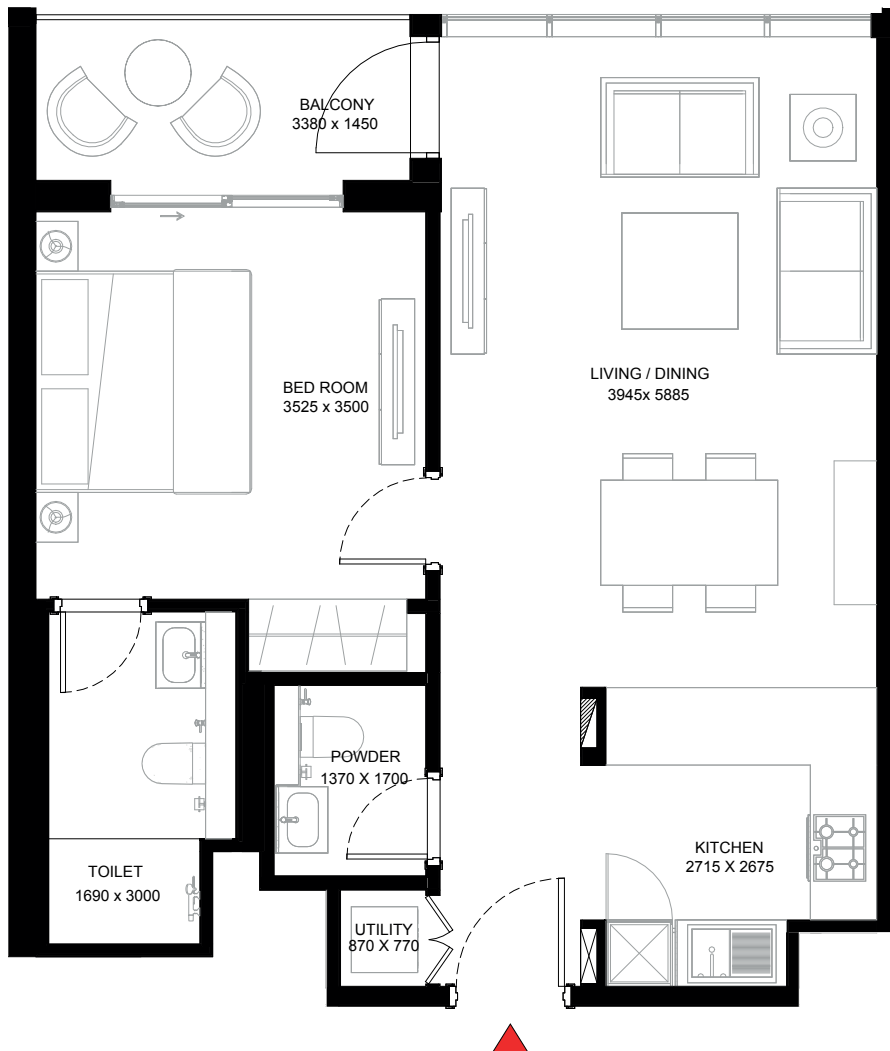
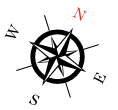

List of unit numbers with this unit plan:

### VIEWS

Burj Khalifa, Downtown, Dubai Water Canal, Amenities  
B1009, B1109, B1209, B1309

Burj Khalifa, Downtown, Dubai Water Canal

B1409, B1509, B1609, B1709, B1809, B1909, B2009, B2109, B2209, B2309, B2409, B2509, B2609, B2709, B2809, B2909, B3009, B3109, B3209, B3409, B3509, B3609, B3709, B3809, B3909, B4009, B4109, B4209, B4309, B4409, B4509, B4609, B4709, B4809, B4909, B5009, B5109, B5209, B5309, B5409, B5509, B5609, B5709

Disclaimer: 1. All dimensions are in metric, measured to wall finishes. 2. All materials, dimensions & drawings are approximate. 3. Information is subject to change without notice, at developer's absolute discretion. 4. Actual area may vary from the stated area. 5. Drawing are not to scale. 6. All images used are for illustrative purpose only and do not represent the actual size, features, specifications, fittings and furnishings. 7. The developer reserves the right to make revisions/ alterations, at its absolute discretion, without any liability whatsoever.

# 1 BEDROOM APARTMENT

## TYPE E (with powder room + balcony)

**TOTAL SALEABLE AREA**

SUITE = 788.13 SQ.FT.

BALCONY = 66.84 SQ.FT.

TOTAL = 854.97 SQ.FT.

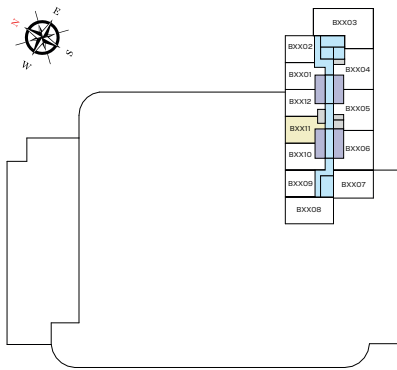

LEVEL 10 - 32

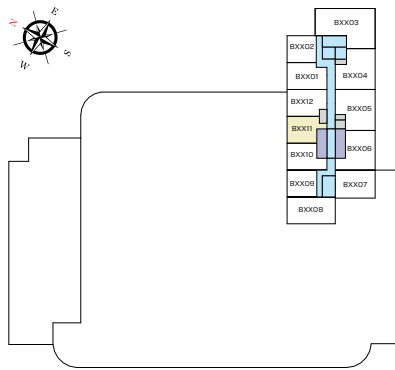

LEVEL 34 - 57

UNIT

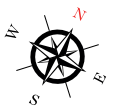

List of unit numbers with this unit plan:

### VIEWS

Burj Khalifa, Downtown, Dubai Water Canal, Amenities  
B1011, B1111, B1211, B1311

Burj Khalifa, Downtown, Dubai Water Canal

B1411, B1511, B1611, B1711, B1811, B1911, B2011, B2111, B2211, B2311, B2411, B2511, B2611, B2711, B2811, B2911, B3011, B3111, B3211, B3411, B3511, B3611, B3711, B3811, B3911, B4011, B4111, B4211, B4311, B4411, B4511, B4611, B4711, B4811, B4911, B5011, B5111, B5211, B5311, B5411, B5511, B5611, B5711

Disclaimer: 1. All dimensions are in metric, measured to wall finishes. 2. All materials, dimensions & drawings are approximate. 3. Information is subject to change without notice, at developer's absolute discretion. 4. Actual area may vary from the stated area. 5. Drawing are not to scale. 6. All images used are for illustrative purpose only and do not represent the actual size, features, specifications, fittings and furnishings. 7. The developer reserves the right to make revisions/ alterations, at its absolute discretion, without any liability whatsoever.

# 1 BEDROOM APARTMENT

TYPE E (with powder room + balcony) - VARIANT 1

**TOTAL SALEABLE AREA**

SUITE = 788.13 SQ.FT.

BALCONY = 66.84 SQ.FT.

TOTAL = 854.97 SQ.FT.

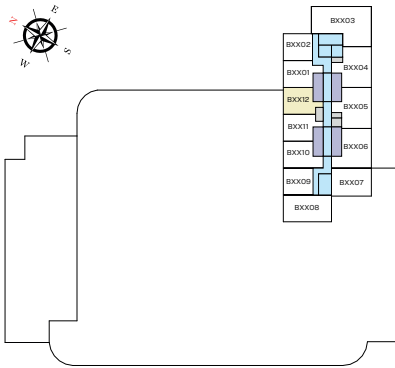

LEVEL 10 - 32

UNIT

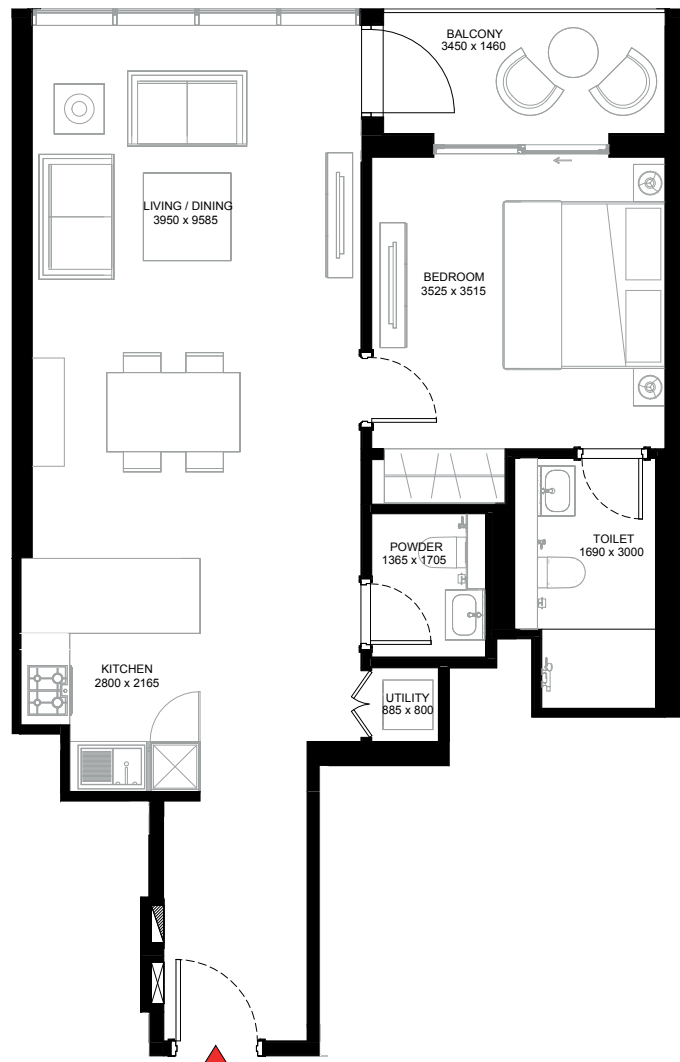
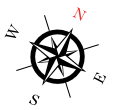

List of unit numbers with this unit plan:

## VIEWS

Burj Khalifa, Downtown, Dubai Water Canal, Amenities

B1012, B1112, B1212, B1312

Burj Khalifa, Downtown, Dubai Water Canal

B1412, B1512, B1612, B1712, B1812, B1912, B2012, B2112, B2212, B2312, B2412, B2512, B2612, B2712, B2812, B2912, B3012, B3112, B3212

Disclaimer: 1. All dimensions are in metric, measured to wall finishes. 2. All materials, dimensions & drawings are approximate. 3. Information is subject to change without notice, at developer's absolute discretion. 4. Actual area may vary from the stated area. 5. Drawing are not to scale. 6. All images used are for illustrative purpose only and do not represent the actual size, features, specifications, fittings and furnishings. 7. The developer reserves the right to make revisions/ alterations, at its absolute discretion, without any liability whatsoever.

# 1 BEDROOM APARTMENT

## TYPE F (with powder room + balcony)

**TOTAL SALEABLE AREA**

SUITE = 770.70 SQ.FT.

BALCONY = 66.41 SQ.FT.

TOTAL = 837.11 SQ.FT.

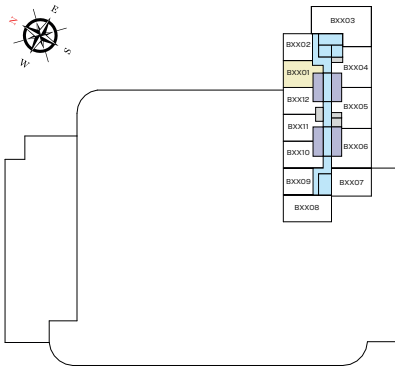

LEVEL 10 - 32

UNIT



List of unit numbers with this unit plan:

### VIEWS

Burj Khalifa, Downtown, Dubai Water Canal, Amenities  
B1001, B1101, B1201, B1301

Burj Khalifa, Downtown, Dubai Water Canal  
B1401, B1501, B1601, B1701, B1801, B1901, B2001, B2101, B2201, B2301, B2401, B2501, B2601, B2701, B2801, B2901, B3001, B3101, B3201

Disclaimer: 1. All dimensions are in metric, measured to wall finishes. 2. All materials, dimensions & drawings are approximate. 3. Information is subject to change without notice, at developer's absolute discretion. 4. Actual area may vary from the stated area. 5. Drawing are not to scale. 6. All images used are for illustrative purpose only and do not represent the actual size, features, specifications, fittings and furnishings. 7. The developer reserves the right to make revisions/ alterations, at its absolute discretion, without any liability whatsoever.

# 1 BEDROOM APARTMENT

## TYPE G (with powder room + balcony)

**TOTAL SALEABLE AREA**

SUITE = 779.52 SQ.FT.

BALCONY = 66.84 SQ.FT.

TOTAL = 846.36 SQ.FT.

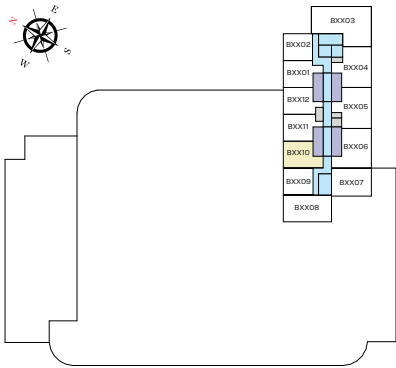

LEVEL 10 - 32

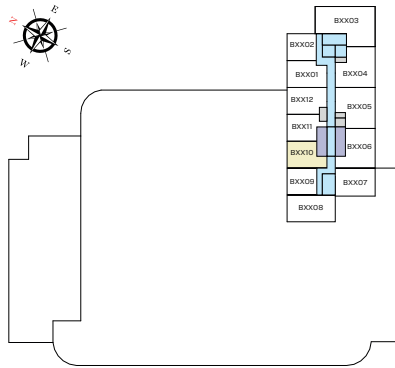

LEVEL 34 - 57

UNIT

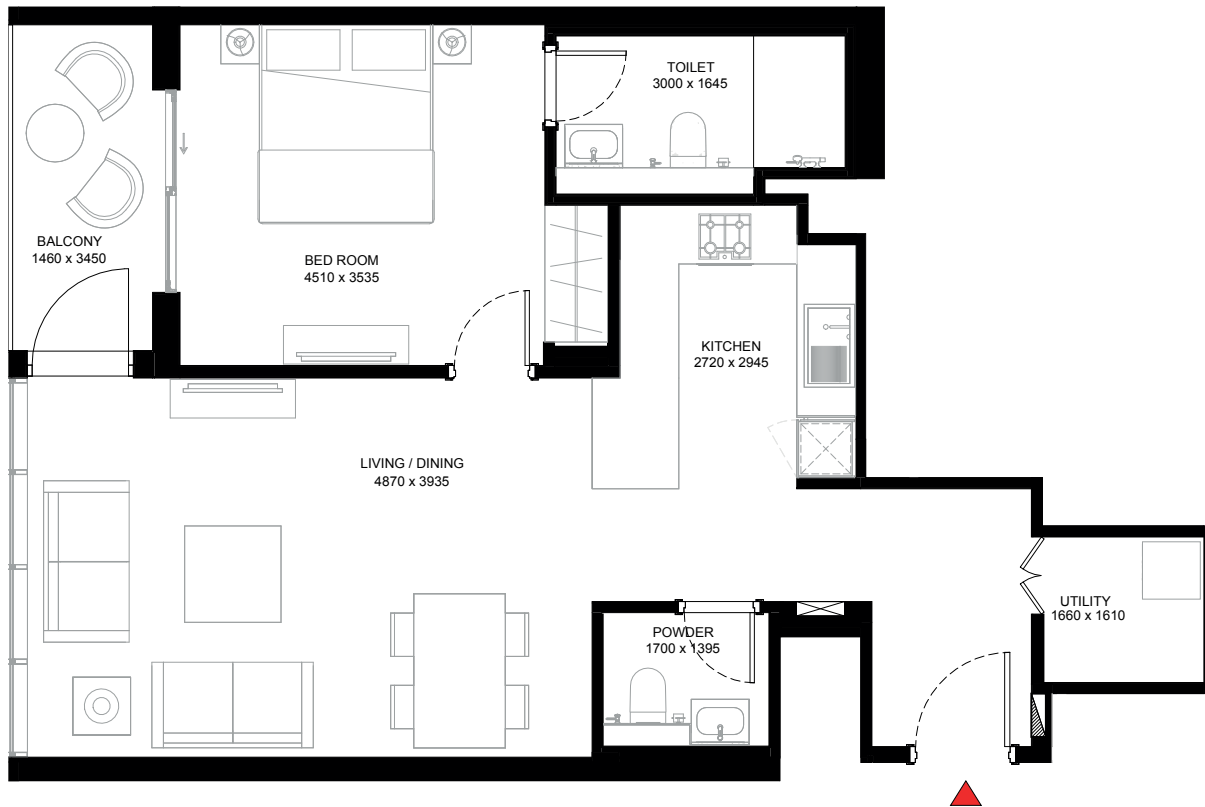
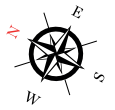

List of unit numbers with this unit plan:

### VIEWS

Burj Khalifa, Downtown, Dubai Water Canal, Amenities  
B1010, B1110, B1210, B1310

Burj Khalifa, Downtown, Dubai Water Canal

B1410, B1510, B1610, B1710, B1810, B1910, B2010, B2110, B2210, B2310, B2410, B2510, B2610, B2710, B2810, B2910, B3010, B3110, B3210, B3410, B3510, B3610, B3710, B3810, B3910, B4010, B4110, B4210, B4310, B4410, B4510, B4610, B4710, B4810, B4910, B5010, B5110, B5210, B5310, B5410, B5510, B5610, B5710

Disclaimer: 1. All dimensions are in metric, measured to wall finishes. 2. All materials, dimensions & drawings are approximate. 3. Information is subject to change without notice, at developer's absolute discretion. 4. Actual area may vary from the stated area. 5. Drawing are not to scale. 6. All images used are for illustrative purpose only and do not represent the actual size, features, specifications, fittings and furnishings. 7. The developer reserves the right to make revisions/ alterations, at its absolute discretion, without any liability whatsoever.

# 1 BEDROOM APARTMENT

## TYPE H (with powder room + balcony)

**TOTAL SALEABLE AREA**

SUITE = 697.39 SQ.FT.

BALCONY = 71.69 SQ.FT.

TOTAL = 769.08 SQ.FT.

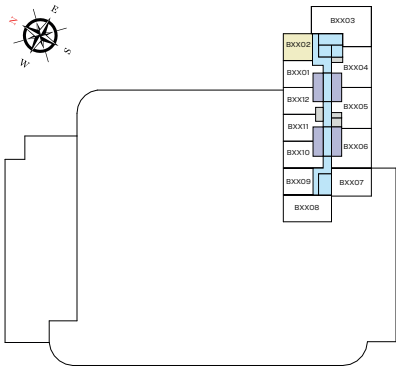

LEVEL 10 - 32

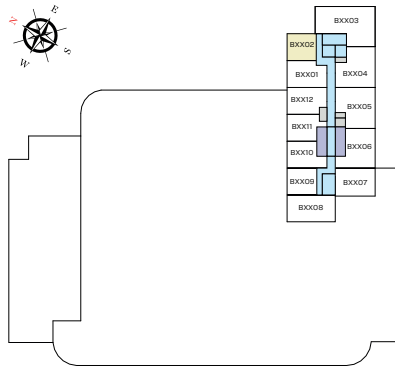

LEVEL 34 - 57

UNIT

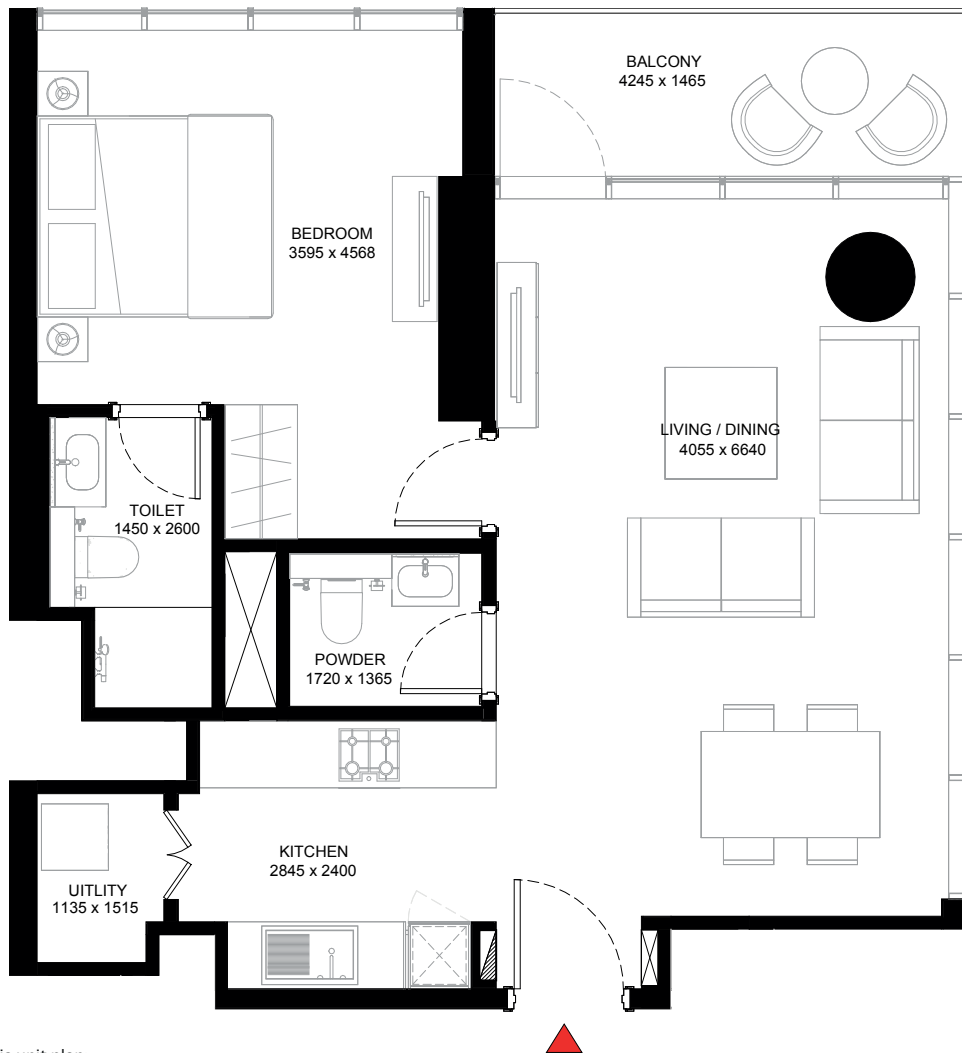
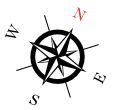

List of unit numbers with this unit plan:

### VIEWS

Burj Khalifa, Downtown, Dubai Water Canal, Amenities  
B1002, B1102, B1202, B1302

Burj Khalifa, Downtown, Dubai Water Canal

B1402, B1502, B1602, B1702, B1802, B1902, B2002, B2102, B2202, B2302, B2402, B2502, B2602, B2702, B2802, B2902, B3002, B3102, B3202, B3402, B3502, B3602, B3702, B3802, B3902, B4002, B4102, B4202, B4302, B4402, B4502, B4602, B4702, B4802, B4902, B5002, B5102, B5202, B5302, B5402, B5502, B5602, B5702

Disclaimer: 1. All dimensions are in metric, measured to wall finishes. 2. All materials, dimensions & drawings are approximate. 3. Information is subject to change without notice, at developer's absolute discretion. 4. Actual area may vary from the stated area. 5. Drawing are not to scale. 6. All images used are for illustrative purpose only and do not represent the actual size, features, specifications, fittings and furnishings. 7. The developer reserves the right to make revisions/ alterations, at its absolute discretion, without any liability whatsoever.

# 1.5 BEDROOM APARTMENT

TYPE D (with study and powder room + balcony)

## TOTAL SALEABLE AREA

SUITE = 934.20 SQ.FT.  
BALCONY = 66.52 SQ.FT.  
TOTAL = 1,000.72 SQ.FT.

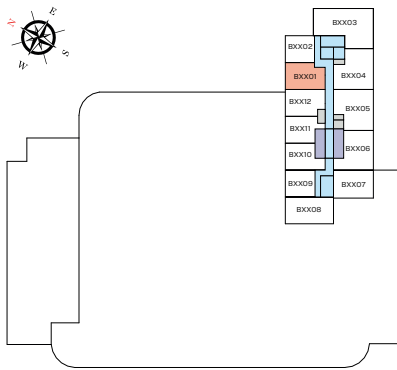

LEVEL 34 - 57

UNIT

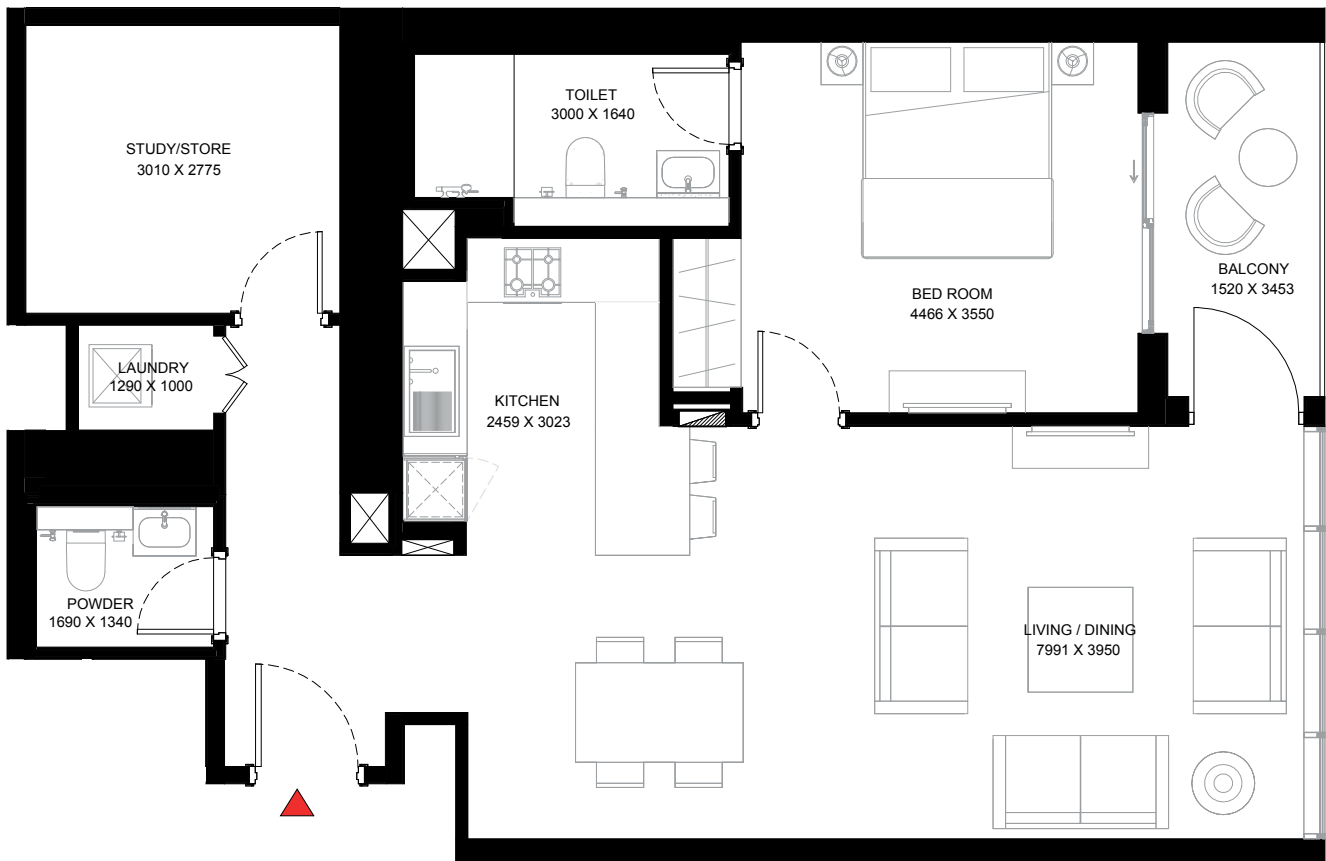

List of unit numbers with this unit plan:

## VIEWS

Burj Khalifa, Downtown, Dubai Water Canal

B3401, B3501, B3601, B3701, B3801, B3901, B4001, B4101, B4201, B4301, B4401, B4501, B4601, B4701, B4801, B4901, B5001, B5101, B5201, B5301, B5401, B5501, B5601, B5701

Disclaimer: 1. All dimensions are in metric, measured to wall finishes. 2. All materials, dimensions & drawings are approximate. 3. Information is subject to change without notice, at developer's absolute discretion. 4. Actual area may vary from the stated area. 5. Drawing are not to scale. 6. All images used are for illustrative purpose only and do not represent the actual size, features, specifications, fittings and furnishings. 7. The developer reserves the right to make revisions/ alterations, at its absolute discretion, without any liability whatsoever.

# 1.5 BEDROOM APARTMENT

TYPE E (with study and powder room + balcony)

**TOTAL SALEABLE AREA**

SUITE = 934.31 SQ.FT.

BALCONY = 66.84 SQ.FT.

TOTAL = 1,001.15 SQ.FT.

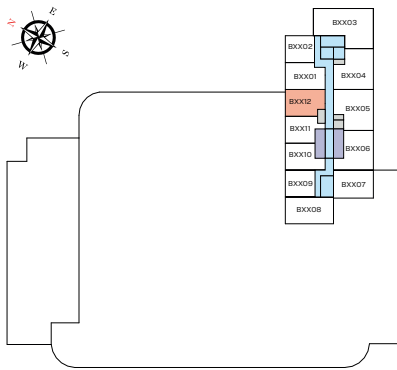

LEVEL 34 - 57

UNIT

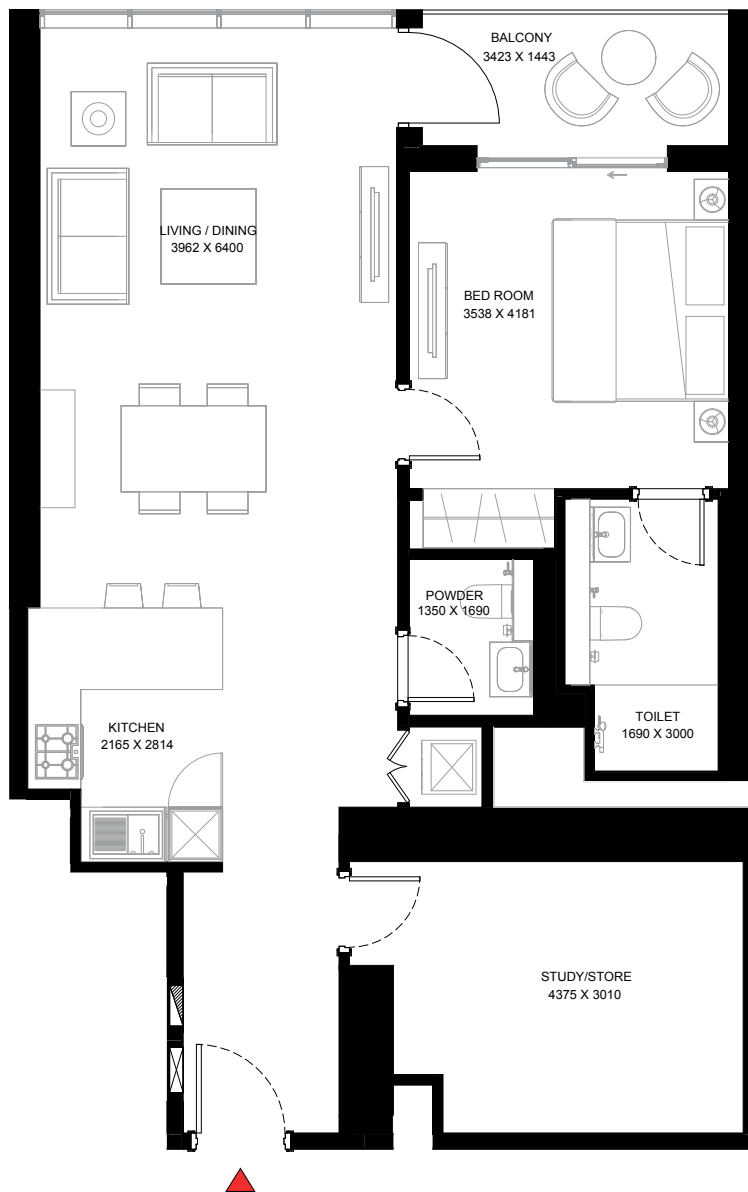
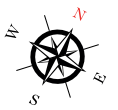

List of unit numbers with this unit plan:

## VIEWS

Burj Khalifa, Downtown, Dubai Water Canal

B3412, B3512, B3612, B3712, B3812, B3912, B4012, B4112, B4212, B4312, B4412, B4512, B4612, B4712, B4812, B4912, B5012, B5112, B5212, B5312, B5412, B5512, B5612, B5712

Disclaimer: 1. All dimensions are in metric, measured to wall finishes. 2. All materials, dimensions & drawings are approximate. 3. Information is subject to change without notice, at developer's absolute discretion. 4. Actual area may vary from the stated area. 5. Drawing are not to scale. 6. All images used are for illustrative purpose only and do not represent the actual size, features, specifications, fittings and furnishings. 7. The developer reserves the right to make revisions/ alterations, at its absolute discretion, without any liability whatsoever.



# 2 BEDROOM APARTMENT

TYPE C (with maid room and powder room + 2 balconies)

**TOTAL SALEABLE AREA**

SUITE = 1,142.16 SQ.FT.  
 BALCONY = 147.57 SQ.FT.  
 TOTAL = 1,289.73 SQ.FT.

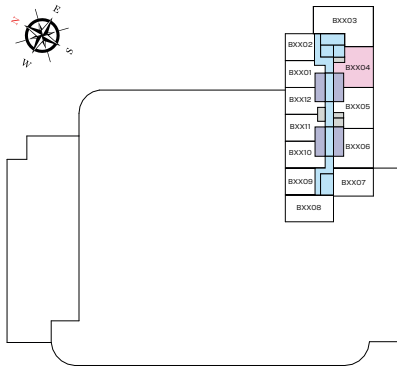

LEVEL 10 - 32

UNIT

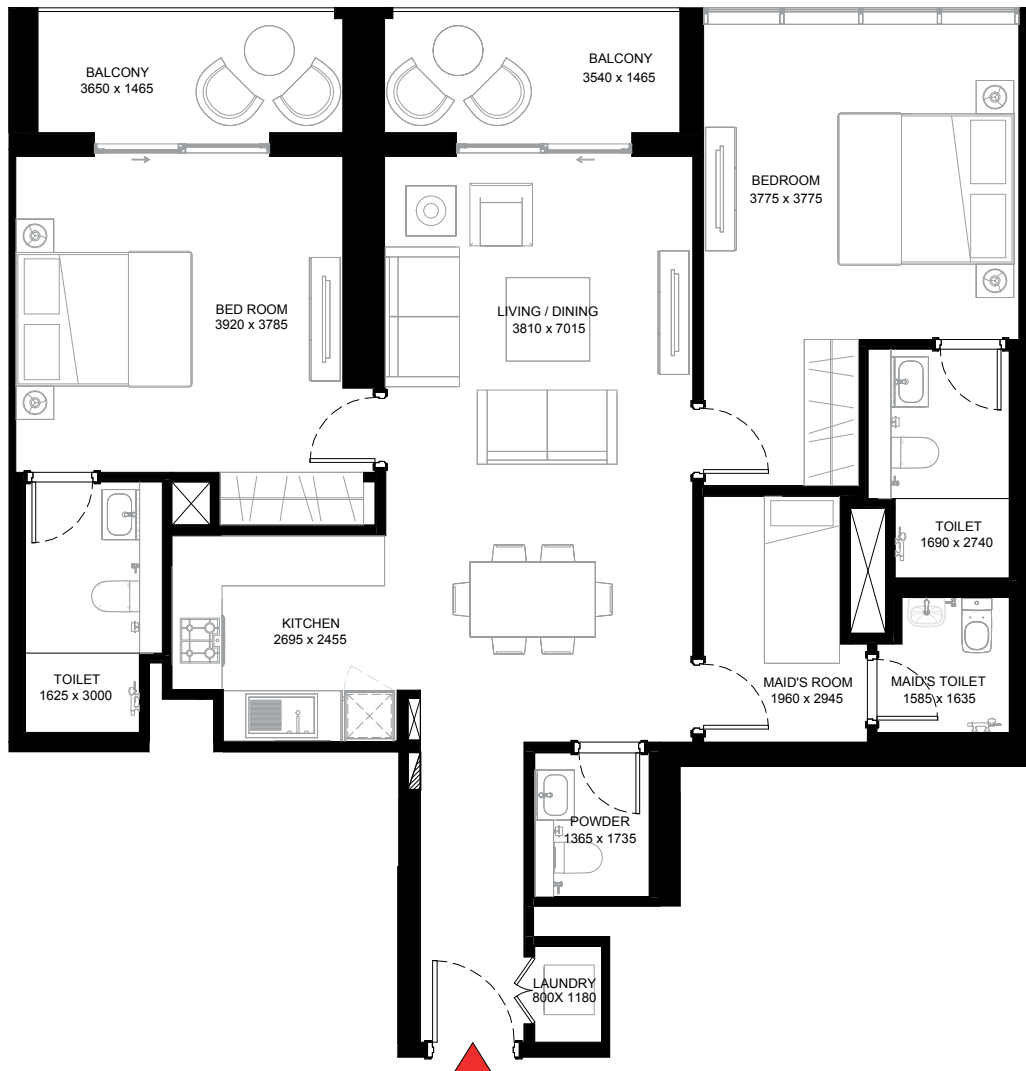

List of unit numbers with this unit plan:

## VIEWS

Ras Al Khor Sanctuary, Hartland

B1004, B1104, B1204, B1304, B1404, B1504, B1604, B1704, B1804, B1904, B2004, B2104, B2204, B2304, B2404, B2504, B2604, B2704, B2804, B2904, B3004, B3104, B3204

Disclaimer: 1. All dimensions are in metric, measured to wall finishes. 2. All materials, dimensions & drawings are approximate. 3. Information is subject to change without notice, at developer's absolute discretion. 4. Actual area may vary from the stated area. 5. Drawing are not to scale. 6. All images used are for illustrative purpose only and do not represent the actual size, features, specifications, fittings and furnishings. 7. The developer reserves the right to make revisions/ alterations, at its absolute discretion, without any liability whatsoever.

# 2 BEDROOM APARTMENT

TYPE C (with maid room and powder room + 2 balconies) - VARIANT 1

## TOTAL SALEABLE AREA

SUITE = 1,127.95 SQ.FT.  
BALCONY = 147.57 SQ.FT.  
TOTAL = 1,275.52 SQ.FT.

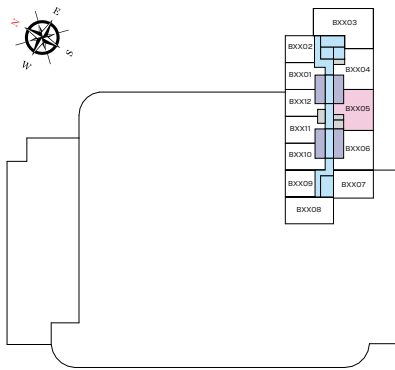

LEVEL 19 & 29

UNIT

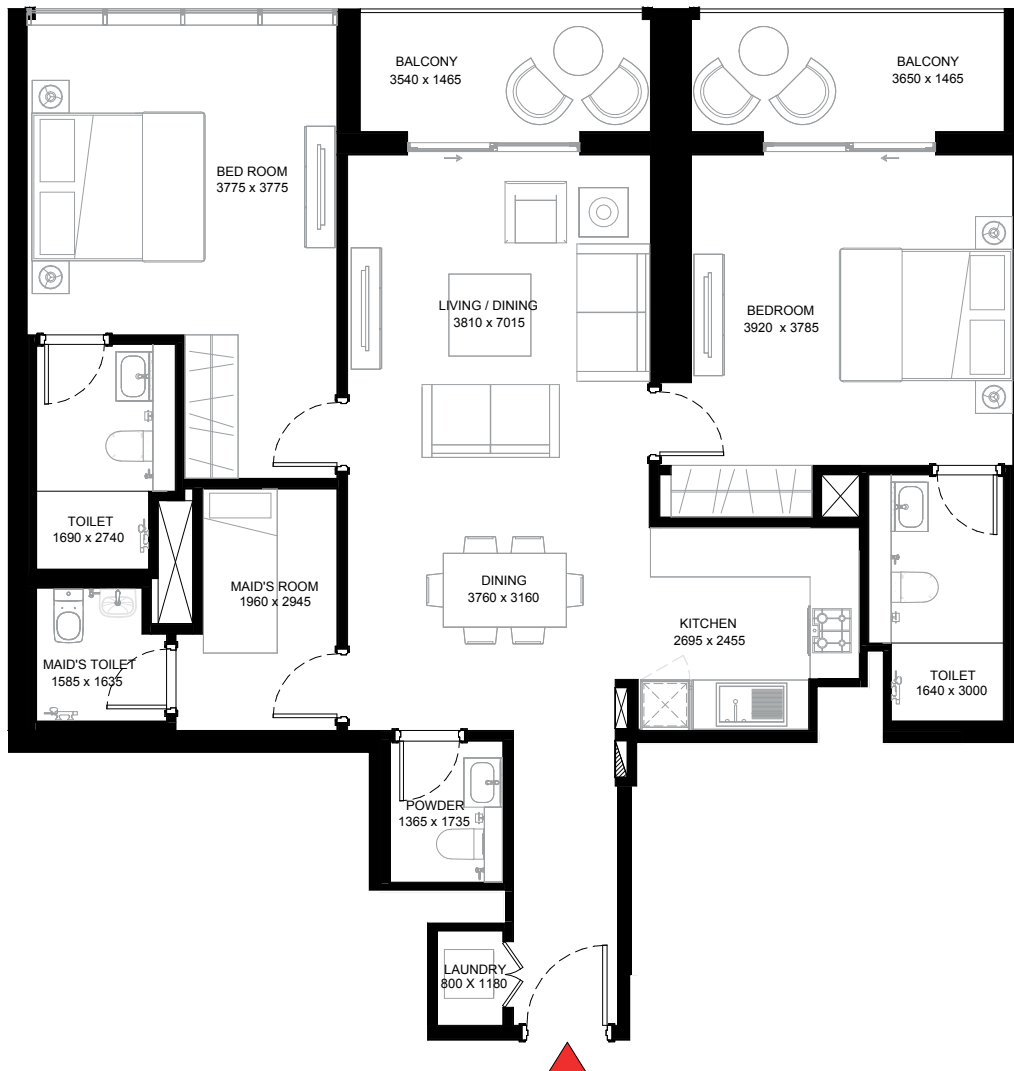

List of unit numbers with this unit plan:

## VIEWS

Ras Al Khor Sanctuary, Hartland  
B1905, B2905

Disclaimer: 1. All dimensions are in metric, measured to wall finishes. 2. All materials, dimensions & drawings are approximate. 3. Information is subject to change without notice, at developer's absolute discretion. 4. Actual area may vary from the stated area. 5. Drawing are not to scale. 6. All images used are for illustrative purpose only and do not represent the actual size, features, specifications, fittings and furnishings. 7. The developer reserves the right to make revisions/ alterations, at its absolute discretion, without any liability whatsoever.

# 2 BEDROOM APARTMENT

TYPE D (with balcony)

**TOTAL SALEABLE AREA**

SUITE = 1,008.26 SQ.FT.

BALCONY = 65.34 SQ.FT.

TOTAL = 1,073.60 SQ.FT.

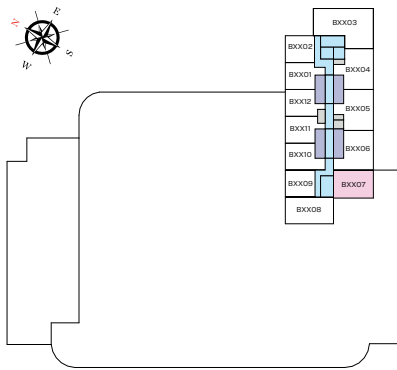

LEVEL 10 - 32

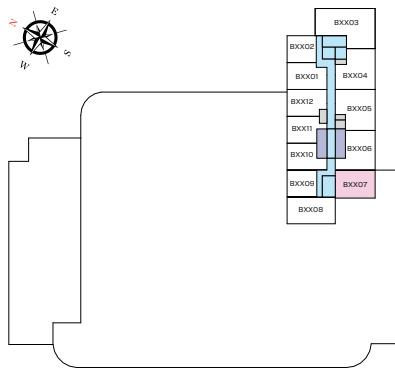

LEVEL 34 - 57

UNIT

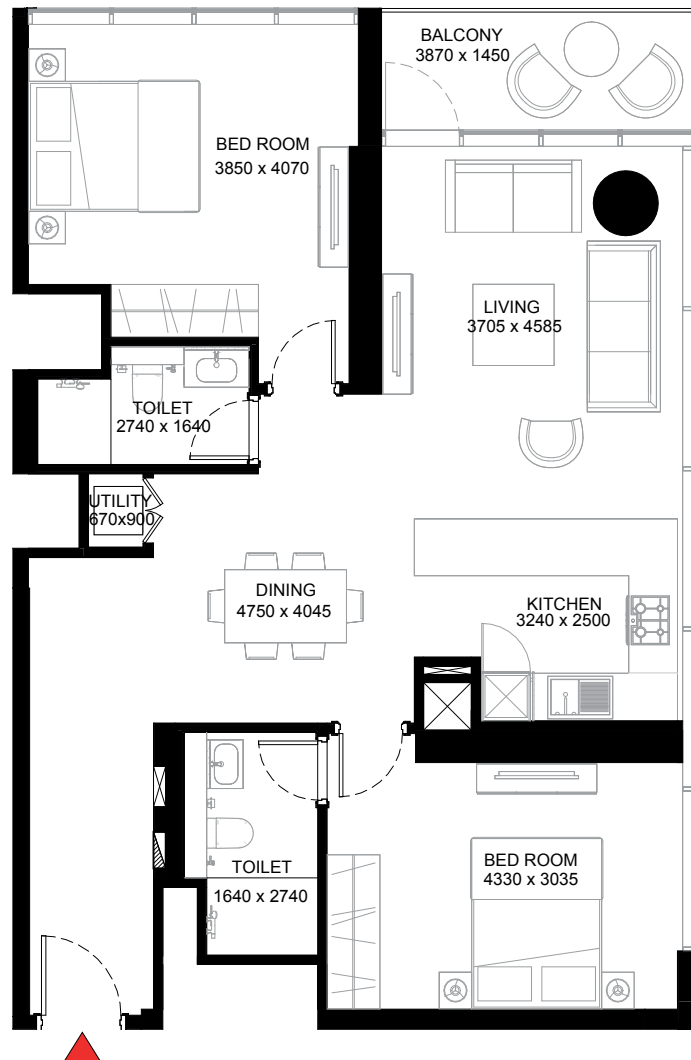

List of unit numbers with this unit plan:

## VIEWS

Ras Al Khor Sanctuary, Hartland

B1007, B1107, B1207, B1307, B1407, B1507, B1607, B1707, B1807, B1907, B2007, B2107, B2207, B2307, B2407, B2507, B2607, B2707, B2807, B2907, B3007, B3107, B3207, B3407, B3507, B3607, B3707, B3807, B3907, B4007, B4107, B4207, B4307, B4407, B4507, B4607, B4707, B4807, B4907, B5007, B5107, B5207, B5307, B5407, B5507, B5607, B5707

Disclaimer: 1. All dimensions are in metric, measured to wall finishes. 2. All materials, dimensions & drawings are approximate. 3. Information is subject to change without notice, at developer's absolute discretion. 4. Actual area may vary from the stated area. 5. Drawing are not to scale. 6. All images used are for illustrative purpose only and do not represent the actual size, features, specifications, fittings and furnishings. 7. The developer reserves the right to make revisions/ alterations, at its absolute discretion, without any liability whatsoever.

# 2 BEDROOM APARTMENT

TYPE E (with maid room and powder room + 2 balconies)

## TOTAL SALEABLE AREA

SUITE = 1,142.48 SQ.FT.  
BALCONY = 143.91 SQ.FT.  
TOTAL = 1,286.39 SQ.FT.

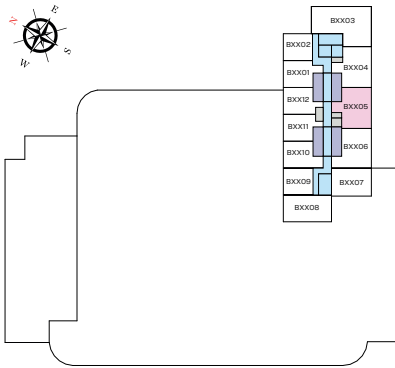

LEVEL 10 - 18, 20 - 28 & 30 - 32

UNIT

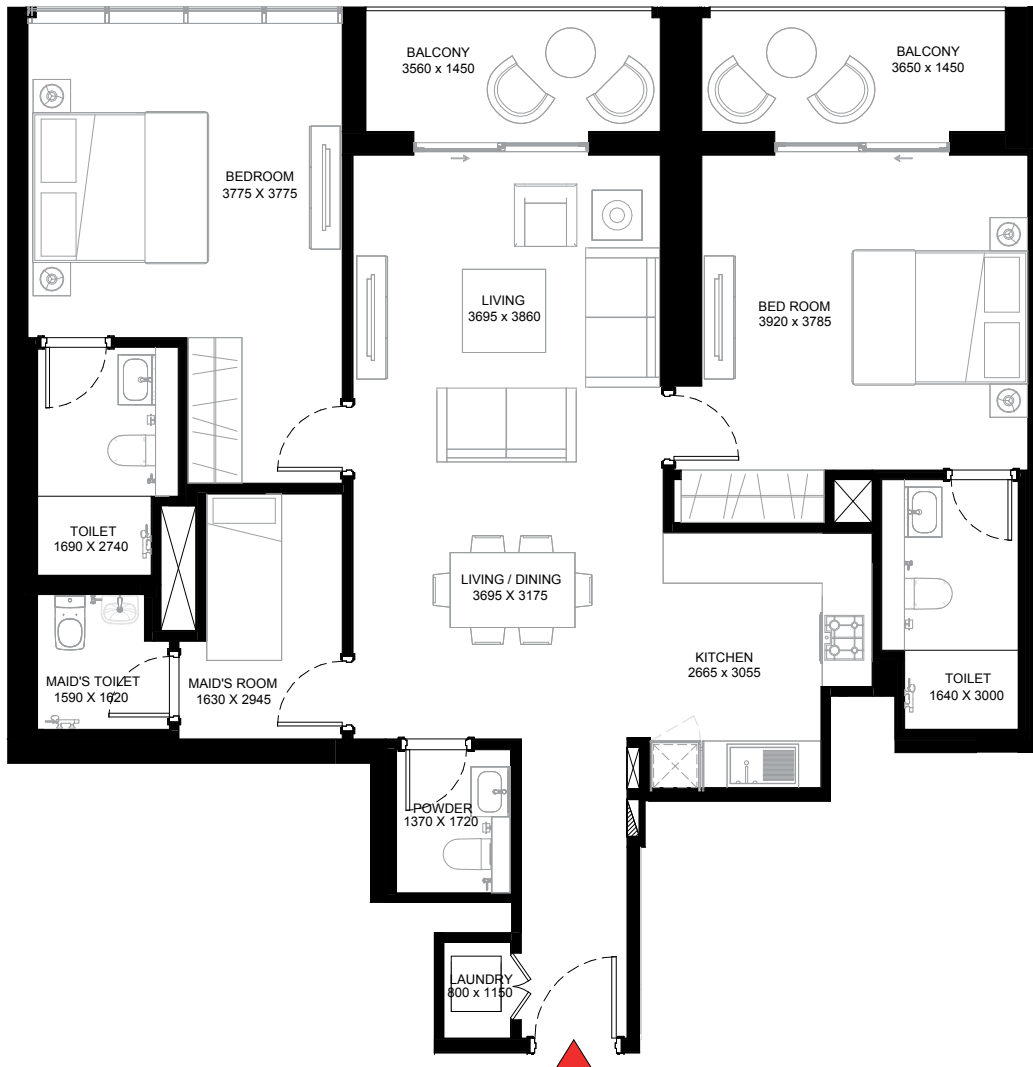

List of unit numbers with this unit plan:

## VIEWS

Ras Al Khor Sanctuary, Hartland

B1005, B1105, B1205, B1305, B1405, B1505, B1605, B1705, B1805, B2005, B2105, B2205, B2305, B2405, B2505, B2605, B2705, B2805, B3005, B3105, B3205

Disclaimer: 1. All dimensions are in metric, measured to wall finishes. 2. All materials, dimensions & drawings are approximate. 3. Information is subject to change without notice, at developer's absolute discretion. 4. Actual area may vary from the stated area. 5. Drawing are not to scale. 6. All images used are for illustrative purpose only and do not represent the actual size, features, specifications, fittings and furnishings. 7. The developer reserves the right to make revisions/ alterations, at its absolute discretion, without any liability whatsoever.

# 2.5 BEDROOM APARTMENT

TYPE C (with study and maid room + balcony)

## TOTAL SALEABLE AREA

SUITE = 1,202.54 SQ.FT.

BALCONY = 67.92 SQ.FT.

TOTAL = 1,270.46 SQ.FT.

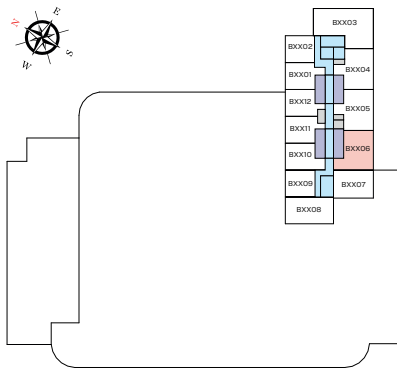

LEVEL 10 - 32

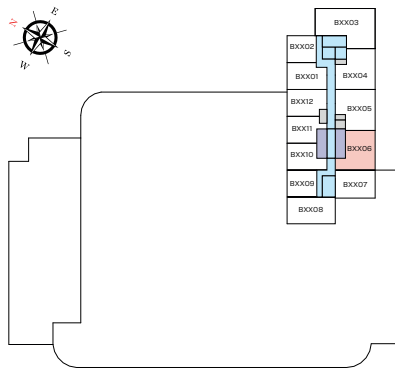

LEVEL 34 - 57

UNIT



List of unit numbers with this unit plan:

## VIEWS

Ras Al Khor Sanctuary, Hartland

B1006, B1106, B1206, B1306, B1406, B1506, B1606, B1706, B1806, B1906, B2006, B2106, B2206, B2306, B2406, B2506, B2606, B2706, B2806, B2906, B3006, B3106, B3206, B3406, B3506, B3606, B3706, B3806, B3906, B4006, B4106, B4206, B4306, B4406, B4506, B4606, B4706, B4806, B4906, B5006, B5106, B5206, B5306, B5406, B5506, B5606, B5706

Disclaimer: 1. All dimensions are in metric, measured to wall finishes. 2. All materials, dimensions & drawings are approximate. 3. Information is subject to change without notice, at developer's absolute discretion. 4. Actual area may vary from the stated area. 5. Drawing are not to scale. 6. All images used are for illustrative purpose only and do not represent the actual size, features, specifications, fittings and furnishings. 7. The developer reserves the right to make revisions/ alterations, at its absolute discretion, without any liability whatsoever.

# 2.5 BEDROOM APARTMENT

TYPE D (with study and maid room + 2 balconies)

## TOTAL SALEABLE AREA

SUITE = 1,297.05 SQ.FT.  
 BALCONY = 147.57 SQ.FT.  
 TOTAL = 1,444.62 SQ.FT.

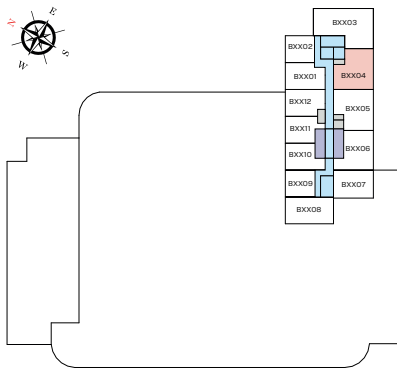

LEVEL 34 - 57

UNIT



List of unit numbers with this unit plan:

## VIEWS

Ras Al Khor Sanctuary, Hartland

B3404, B3504, B3604, B3704, B3804, B3904, B4004, B4104, B4204, B4304, B4404, B4504, B4604, B4704, B4804, B4904, B5004, B5104, B5204, B5304, B5404, B5504, B5604, B5704

Disclaimer: 1. All dimensions are in metric, measured to wall finishes. 2. All materials, dimensions & drawings are approximate. 3. Information is subject to change without notice, at developer's absolute discretion. 4. Actual area may vary from the stated area. 5. Drawing are not to scale. 6. All images used are for illustrative purpose only and do not represent the actual size, features, specifications, fittings and furnishings. 7. The developer reserves the right to make revisions/ alterations, at its absolute discretion, without any liability whatsoever.

# 2.5 BEDROOM APARTMENT

TYPE D (with study and maid room + 2 balconies) - VARIANT 1

## TOTAL SALEABLE AREA

SUITE = 1,282.95 SQ.FT.  
 BALCONY = 147.57 SQ.FT.  
 TOTAL = 1,430.52 SQ.FT.

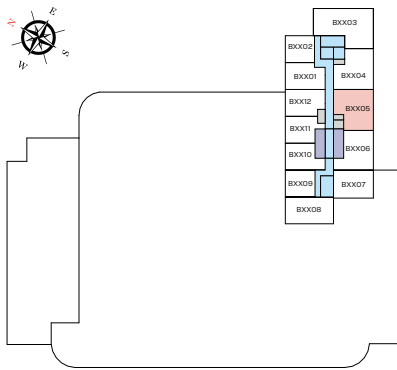

LEVEL 34 - 57

UNIT

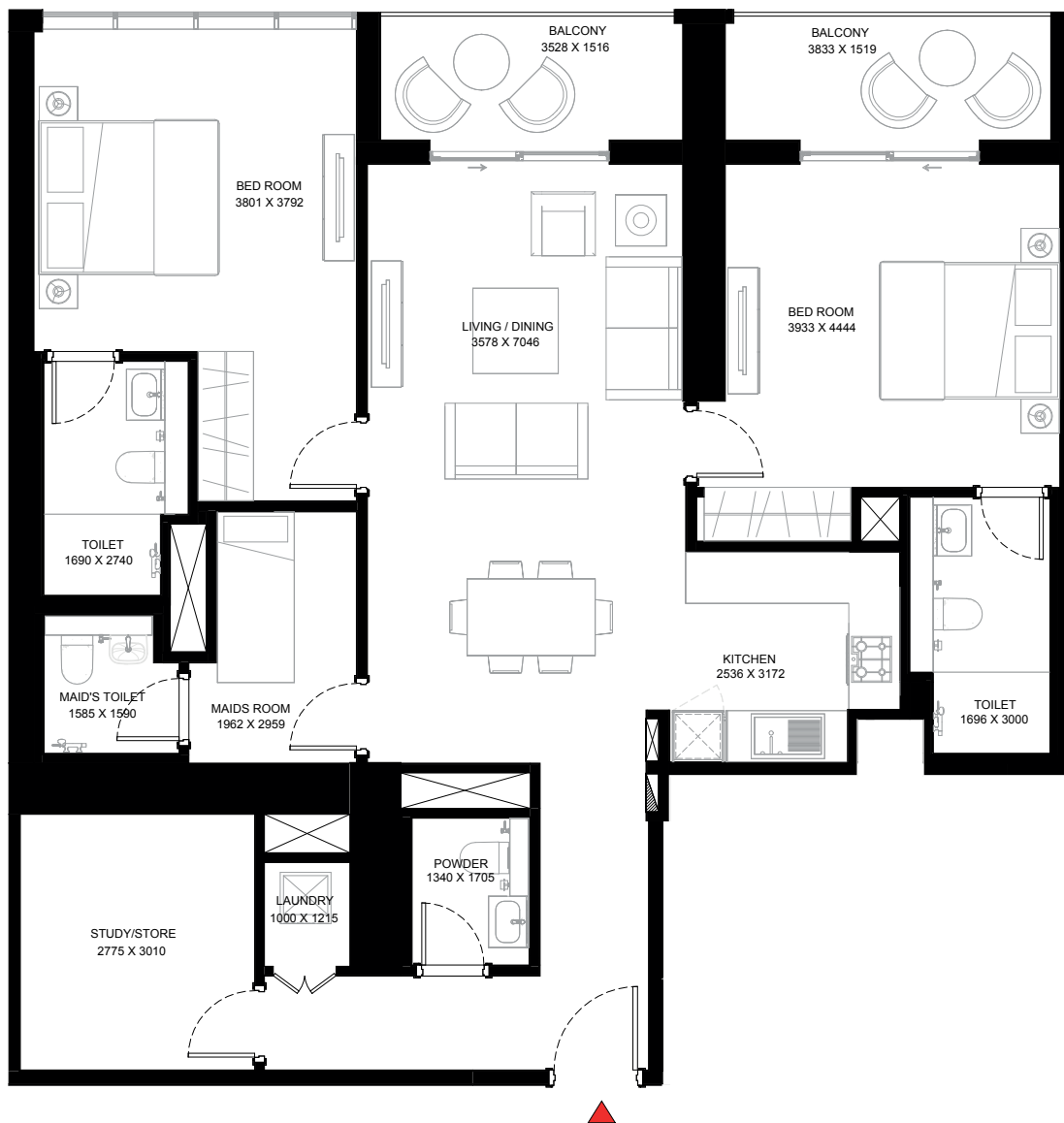

List of unit numbers with this unit plan:

## VIEWS

Ras Al Khor Sanctuary, Hartland  
 B3905, B4905

Disclaimer: 1. All dimensions are in metric, measured to wall finishes. 2. All materials, dimensions & drawings are approximate. 3. Information is subject to change without notice, at developer's absolute discretion. 4. Actual area may vary from the stated area. 5. Drawing are not to scale. 6. All images used are for illustrative purpose only and do not represent the actual size, features, specifications, fittings and furnishings. 7. The developer reserves the right to make revisions/ alterations, at its absolute discretion, without any liability whatsoever.

# 2.5 BEDROOM APARTMENT

TYPE E (with study and maid room + 2 balconies)

## TOTAL SALEABLE AREA

SUITE = 1,297.80 SQ.FT.

BALCONY = 143.91 SQ.FT.

TOTAL = 1,441.71 SQ.FT.

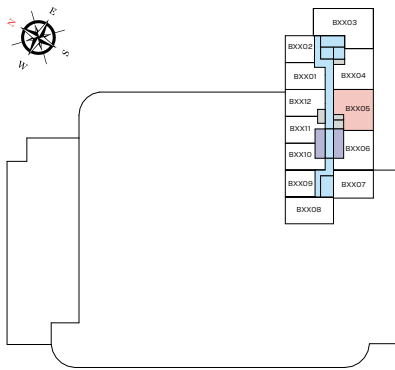

LEVEL 34 - 38, 40 - 48 & 50 - 57

UNIT



List of unit numbers with this unit plan:

## VIEWS

Ras Al Khor Sanctuary, Hartland

B3405, B3505, B3605, B3705, B3805, B4005, B4105, B4205, B4305, B4405, B4505, B4605, B4705, B4805, B5005, B5105, B5205, B5305, B5405, B5505, B5605, B5705

Disclaimer: 1. All dimensions are in metric, measured to wall finishes. 2. All materials, dimensions & drawings are approximate. 3. Information is subject to change without notice, at developer's absolute discretion. 4. Actual area may vary from the stated area. 5. Drawing are not to scale. 6. All images used are for illustrative purpose only and do not represent the actual size, features, specifications, fittings and furnishings. 7. The developer reserves the right to make revisions/ alterations, at its absolute discretion, without any liability whatsoever.



# 3 BEDROOM APARTMENT

TYPE A (with maid room and powder room + balcony)

**TOTAL SALEABLE AREA**

SUITE = 1,180.05 SQ.FT.

BALCONY = 66.41 SQ.FT.

TOTAL = 1,246.46 SQ.FT.

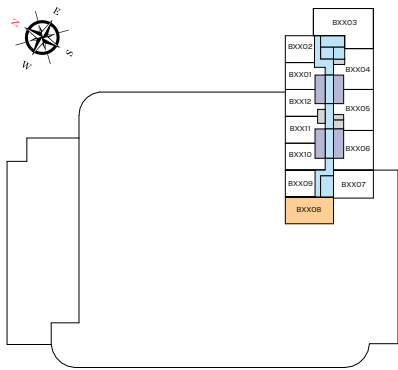

LEVEL 10 - 32

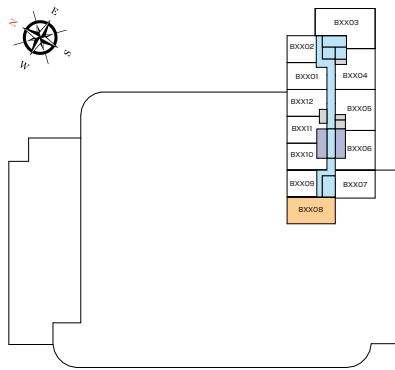

LEVEL 34 - 57

UNIT



List of unit numbers with this unit plan:

## VIEWS

Burj Khalifa, Downtown, Dubai Water Canal, Hartland, Amenities  
B1008, B1108, B1208, B1308

Burj Khalifa, Downtown, Dubai Water Canal

B1408, B1508, B1608, B1708, B1808, B1908, B2008, B2108, B2208, B2308, B2408, B2508, B2608, B2708, B2808, B2908, B3008, B3108, B3208, B3408, B3508, B3608, B3708, B3808, B3908, B4008, B4108, B4208, B4308, B4408, B4508, B4608, B4708, B4808, B4908, B5008, B5108, B5208, B5308, B5408, B5508, B5608, B5708

Disclaimer: 1. All dimensions are in metric, measured to wall finishes. 2. All materials, dimensions & drawings are approximate. 3. Information is subject to change without notice, at developer's absolute discretion. 4. Actual area may vary from the stated area. 5. Drawing are not to scale. 6. All images used are for illustrative purpose only and do not represent the actual size, features, specifications, fittings and furnishings. 7. The developer reserves the right to make revisions/ alterations, at its absolute discretion, without any liability whatsoever.

# 3.5 BEDROOM APARTMENT

TYPE B (with study and maid room + balcony)

**TOTAL SALEABLE AREA**

SUITE = 1,807.05 SQ.FT.

BALCONY = 80.84 SQ.FT.

TOTAL = 1,887.89 SQ.FT.

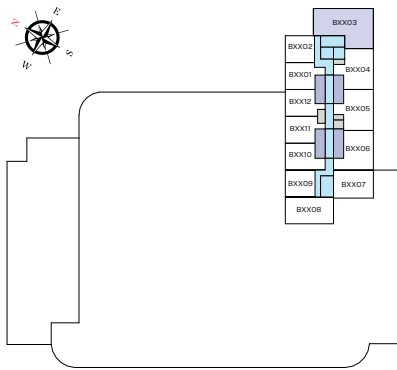

LEVEL 10 - 32

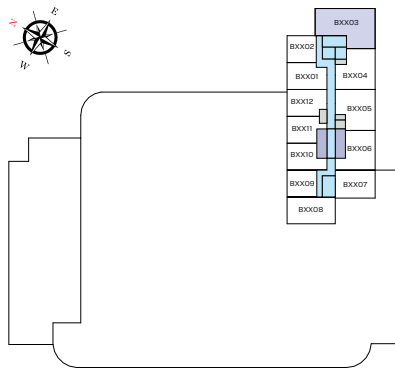

LEVEL 34 - 57

UNIT

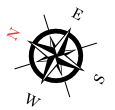

List of unit numbers with this unit plan:

## VIEWS

Burj Khalifa, Downtown, Dubai Water Canal, Hartland

B1003, B1103, B1203, B1303, B1403, B1503, B1603, B1703, B1803, B1903, B2003, B2103, B2203, B2303, B2403, B2503, B2603, B2703, B2803, B2903, B3003, B3103, B3203, B3403, B3503, B3603, B3703, B3803, B3903, B4003, B4103, B4203, B4303, B4403, B4503, B4603, B4703, B4803, B4903, B5003, B5103

Burj Khalifa, Downtown, Dubai Water Canal, Ras Al Khor Sanctuary, Hartland

B5203, B5303, B5403, B5503, B5603, B5703

Disclaimer: 1. All dimensions are in metric, measured to wall finishes. 2. All materials, dimensions & drawings are approximate. 3. Information is subject to change without notice, at developer's absolute discretion. 4. Actual area may vary from the stated area. 5. Drawing are not to scale. 6. All images used are for illustrative purpose only and do not represent the actual size, features, specifications, fittings and furnishings. 7. The developer reserves the right to make revisions/ alterations, at its absolute discretion, without any liability whatsoever.



**SOBHA**  
REALTY